



# USE AND MAINTENANCE MANUAL

**Machine:** DIESEL FUEL PUMP  
**Models:** PA1 70A, PA2 80, PA2 100, PA3 150



THE USE AND MAINTENANCE MANUAL MUST BE CAREFULLY STORED NEAR THE MACHINE IN AN ENVIRONMENT PROTECTED AGAINST HUMIDITY AND HEAT. THE MANUAL MUST ACCOMPANY THE MACHINE IF SOLD. IT IS PROHIBITED TO DAMAGE, MODIFY OR REMOVE ANY PART OF THE MANUAL.

## EC DECLARATION OF CONFORMITY





(Annex II A DIR. 2006/42/EC)

### THE MANUFACTURER

We, ADAM PUMPS S.p.A., with our registered office in Via della Resistenza, 46/48, 41011, Campogalliano (MO), ITALY; represented by Davide Stassi, authorised to compile the relevant technical file at the undersigned premises,

### DECLARES THAT THE MACHINE

Used as a diesel fuel pump to be integrated into a system for transferring fuel from a gravity tank.

	 Adam Pumps	  
<b>Batch of</b>	_____	
<b>Model</b>	Code : PA7A00	
<b>Description</b>	PUMP PA1 70 - 230V	
<b>Technical specifications</b>	230 Volt - 50 Hz - IP 55 - 550W - 2,5 A 2800 rpm - Condensator: 450 v-16 µF	
<b>Weight</b>	Weight Kg.: 8	

### COMPLIES WITH DIRECTIVES

Directive 2006/42/EC of the European Parliament and of the Council of 17 May 2006 on machinery, and amending Directive 95/16/EC.

Directive 2014/30/EU of the European Parliament and of the Council of 26 February 2014 on the harmonisation of the laws of the Member States relating to electromagnetic compatibility.

Directive 2014/35/EU of the European Parliament and of the Council of 26 February 2014 on the harmonisation of the laws of the Member States relating to the making available on the market of electrical equipment designed for use within certain voltage limits.

Directive 2014/68/EU of the European Parliament and of the Council of 15 May 2014 on the harmonisation of the laws of the Member States relating to the making available on the market of pressure equipment.

### Place and date of the document

Campogalliano, 1st October 2015

### The legal representative

*Davide Stassi*

### Adam Pumps spa

Via della Resistenza 46/48 - 41011 Campogalliano (MO) ITALY

Tel +39 059 528128 - Fax +39 059 528437

www.adampumps.com - info@adampumps.com

UM033

11/2017 - rev. 06



TABLE OF CONTENTS	4.3 Storage	7 - TROUBLESHOOTING
1 - GENERAL WARNINGS	5 - INSTALLATION	8 - MAINTENANCE
2 - MACHINE SPECIFICATIONS	5.1 Preliminary checks and positioning the pump	9 - DEMOLITION AND DISPOSAL
2.1 Intended use	5.2 Hydraulic pipe connection	10 - WARRANTY
2.2 Description of the machine	5.3 Remarks on the suction and discharge lines	11 - TECHNICAL SUPPORT
2.3 Technical specifications	5.4 Electrical connection of the pump	12 - ATTACHMENTS
3 - OPERATING CONDITIONS	6 - INTENDED USE	12.1 Exploded views and spare parts list
3.1 Environmental conditions	6.1 Preliminary checks and start-up	12.2 Wiring diagrams
3.2 Power supply	6.2 Daily use	12.3 Overall dimensions and weights
3.3 Allowed fluids / Forbidden fluids	6.3 Noise level	
4 - TRANSPORT AND HANDLING	6.4 Compatibility in an electromagnetic environment	
4.1 Transport		
4.2 Unpacking		

## 1 - GENERAL WARNINGS

**!** *IMPORTANT: It is essential to have understood the entire instruction manual before performing any operation, so as to safeguard operator safety and to avoid potential product damage.*

### Storing the manual:

This manual must be kept intact and fully legible. The end user and the skilled technicians authorised with installation and maintenance of the product in question must be able to consult it at all times.

### Reproduction rights:

This manual is the property of ADAM PUMPS S.p.A., which is the sole owner of all rights provided for by applicable law, including without limitation copyright rules. All rights under these rules belong to ADAM PUMPS S.p.A.: reproduction, even partial, of this manual, its publication, modification, transcription, public disclosure, distribution, marketing in any form, translation and/or development, loan, or any other activity reserved by law to ADAM PUMPS S.p.A.

## 2 - MACHINE SPECIFICATIONS

### 2.1 - INTENDED USE

The pumps described in this manual, once you have unpacked and inserted them in a pumping system, are machines that can fill a receiving tank with diesel fuel sucked from a gravity storage tank.

### 2.2 - DESCRIPTION OF THE MACHINE

The pump is made up of the following parts:

- PUMP** volumetric self-priming rotary vane electric pump fitted with a bypass valve.
- MOTOR** Single-phase and three-phase asynchronous motor, 2-pole, closed (protection class IP55 in compliance with Standard EN60034-5-86), self-ventilating, directly flanged to the pump body.
- FILTER** stainless steel basket filter, can be inspected.

## 2.3 - TECHNICAL SPECIFICATIONS

PUMP MODEL	POWER SUPPLY	(*) MAXIMUM CURRENT [AMP]	(*) RATED POWER [WATT]	(**) WORK CYCLE [MIN]	MAX FLOW RATE [L/MIN]:	INPUT/ OUTPUT [BSP-G]:	(***) NOISE [DBA]
PA1 70A 230V/50Hz	AC 230V / 50Hz	2.9	552W	(S1) Continuous	> 70	1" - 1"	< 70
PA1 70A 230V/60Hz	AC 230V / 60Hz	3.5	667W	(S1) Continuous	> 70	1" - 1"	< 70
PA1 70A 380V/50Hz	AC 380V / 50Hz	1	304W	(S1) Continuous	> 70	1" - 1"	< 70
PA2 80 230V/50Hz	AC 230V / 50Hz	3.5	700W	(S1) Continuous	> 80	1" - 1"	< 80
PA2 100 230V/50Hz	AC 230V / 50Hz	4.1	820W	(S2) 30	> 100	1" - 1"	< 80
PA3 150 230V/50Hz	AC 230V / 50Hz	14.9	3000W	(S2) 30	> 150	1" - 1"	< 87
PA6050 115V/50Hz	AC 115V / 50Hz	10	1035W	(S2) 30	> 70	1" - 1"	< 80
PA6050 115V/60Hz	AC 115V / 60Hz	9	805W	(S2) 30	> 70	1" - 1"	< 80
PA7050 115V/60Hz	AC 115V / 60Hz	9	920W	(S2) 30	> 70	1" - 1"	< 80
PA 8050 115V/60Hz	AC 115V / 60Hz	9	870W	(S2) 30	> 80	1" - 1"	< 80

(\*) The values refer to operation of the pump in bypass (maximum performance)

(\*\*) **CAUTION!** Operation in bypass is allowed only for brief periods (1-2 minutes at most)

(\*\*\*) The noise levels are measured at a distance of 1 metre from the electric pump in normal operating conditions.

In order to maximise performance, pressure losses have to be minimised in the pump suction line as follows:

- shorten the suction pipe as much as possible
- avoid, if possible, installing elbow fittings and/or throttling in the hydraulic circuit
- use a pipe with the same diameter or a diameter larger than the minimum specified in chapter - INSTALLATION
- always keep the filter inside the pump clean and regularly inspected

## 3 - OPERATING CONDITIONS

### 3.1 ENVIRONMENTAL CONDITIONS

#### Temperature

min. -20°C / max. +60°C (\*)

(\*) Caution! The temperature limits shown refer to the components making up the pump and should be respected to prevent any damages or malfunctions from occurring.

#### Relative humidity

max. 90%

### 3.2 - POWER SUPPLY

Depending on the model, the pump must be powered by the single-phase or three-phase AC line whose values are given in the table in section 2.3 - Technical specifications. Powering the pump with values outside these limits can damage the electrical components or cause them to malfunction.

**The maximum power supply variations allowed are:**

Voltage	+/- 5% of the nominal value	Frequency	+/- 2% of the nominal value
---------	-----------------------------	-----------	-----------------------------

### 3.3 - ALLOWED FLUIDS FORBIDDEN FLUIDS

#### Allowed

DIESEL FUEL with 2 to 5.5 cSt viscosity (at 38°C).  
Minimum flash point (MF): 55 °C

#### Forbidden

PETROL	FLAMMABLE LIQUIDS (MF <55°C)
SOLVENTS	LIQUIDS WITH > 20 CST VISCOSITY
FOOD LIQUIDS	CORROSIVE CHEMICALS
WATER	

## 4 - TRANSPORT AND HANDLING

### 4.1 - TRANSPORT

The weight and dimensions of the pump allow it to be easily transported by hand. The pump does not require lifting equipment to move it.

**! CAUTION!** *The Manufacturer shall not be held liable for harm to people or animals or damage to property resulting from use of lifting systems other than those specified.*

Upon receipt, make sure the packaging is intact and in good condition. Any damage must be reported immediately.

### 4.2 - UNPACKING

Unpack the product as follows:

1. Place the box on the floor in the direction drawn on the packaging
2. Carefully open the box, remove the pump and place it on the floor or on a stable surface
3. After ensuring that the pump and any accessories are intact, remove the two plugs and install it as described in the next chapter (5 - INSTALLATION).

### 4.3 - STORAGE

Prior to its use, the pump, still in its original packaging, should be stored in a dry and protected place in an environment with the conditions described in Section 3.1 - Environmental conditions. Failure to follow these instructions may affect proper operation of the pump

## 5 - PRELIMINARY CHECKS

### 5.1 - PRELIMINARY CHECKS AND POSITIONING THE PUMP

Make sure the pump has not been damaged while being transported or stored. Remove any remaining packaging material from the product (e.g. protective caps) and carefully clean the suction and discharge outlets. Install the pump in any position (pump axis either horizontal or vertical), in a place sheltered from

rain and weather events. Position and fix the pump with screws that are suitably sized for the holes on the motor flange. The best performance in terms of noise and vibration reduction is achieved by placing 4 vibration dampers of suitable height between the pump and the base. For the centre distances of the holes, see section 12.3 - Overall dimensions and weights.

**⚠ CAUTION!** *The motors are not explosion-proof. They must not be installed in areas with flammable vapours or open flames.*

## 5.2 - HYDRAULIC PIPE CONNECTION

Before connecting the pump, make sure the tank, fittings and pipes used are clean and free from waste or processing residues. Before connecting the discharge pipe to the pump, we recommend partially filling the pump body with diesel fuel to lubricate and facilitate the priming procedure.

**⚠ CAUTION!** *Do not use couplings or connection fittings with conical threading, as these could damage the pump coupling outlets if tightened too much.*

We recommend using ADAM PUMPS suction and discharge pipes, which are designed specifically for the pump in use; alternatively, respect the dimensions and specifications in the table below.

	PA1 70A		PA2 80 & PA2 100		PA3 150	
	Suction	Discharge	Suction	Discharge	Suction	Discharge
Pump inlet connection thread	1" G - BSP	1" G - BSP	1" G - BSP	1" G - BSP	1" G - BSP	1" G - BSP
Recommended minimum internal diameters	ø25 mm	ø19 mm	ø25 mm	ø25 mm	ø30 mm	ø30 mm
Recommended rated pressure	10 Bar	10 Bar	10 Bar	10 Bar	15 Bar	15 Bar
Pipe suitable for operation under negative pressure	•		•		•	

## 5.3 - REMARKS ON THE SUCTION LINES

### SUCTION LINE

The electric pumps in this manual are self-priming and can draw the liquid from a maximum height of 2 metres. Caution, proper priming and the time required for this can be affected by an automatic nozzle on the discharge line, which prevents normal air extraction from the pipe. It is therefore always advisable to prime the pump for the first time without the automatic nozzle and with the discharge pipe emptied from the liquid. To facilitate the subsequent start-up operations of the pump so that they are immediate, it is always recommended to install a foot valve to prevent the suction pipe from emptying and to keep the pump wet. When the system is in operation, the pump can work with negative pressure at the suction inlet up to 0.5 Bar, after which cavitation phenomena can start with consequent reduction of the flow rate and increase in noise. To prevent this phenomenon from occurring it is important to ensure low suction negative pressure, by using short pipes or pipes with a diameter larger than or the same as those recommended, minimising bends and using large section suction filters and foot valves with the least resistance possible. Moreover, it is very important to keep all suction filters clean to prevent the system resistance from increasing when they are clogged.

### DISCHARGE LINE

The electric pump must be chosen based on the system's specifications. Incorrect combinations of the length of the pipe, of its diameter, of the flow rate of the diesel fuel and/or of the accessories installed on the line, can create a counterpressure on the discharge line that is higher than the maximum set and so cause the pump bypass to open (partially) with consequent reduction in the flow rate dispensed. To prevent this from happening and allow the pump to work properly, the system resistance has to be reduced using pipes that are shorter and/or with a larger diameter and line accessories with less resistance (e.g. an automatic nozzle for greater flow rates).

## 5.4 - ELECTRICAL CONNECTION OF THE PUMP

### SINGLE-PHASE MOTORS

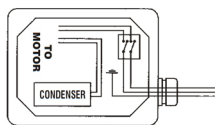

Pumps with single-phase motors are supplied with a 2 m cable and plug.

To change the power cable, open the capacitor box cover and follow the connection diagram to the side.

Single-phase motors are equipped with phase capacitor and double-pole switch.

The capacitor specifications are indicated for each model on the pump's rating plate.

### THREE-PHASE MOTORS

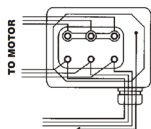

Pumps with three-phase motors are supplied with capacitor box and terminal board.

To connect the electric motor to the power line, open the capacitor box cover and follow the connection diagram to the side.

For proper installation and electrical maintenance of the system, please follow these instructions:

- make sure the power lines are not live when installing or carrying out maintenance operations on the system
- use cables with minimum section, rated voltages and type of installation suitable for the system's specifications
- make sure the three-phase motors are rotating in the right direction
- always connect the pump's earth terminal to the electricity grid's earth line.

**⚠ CAUTION!** *The pumps are provided without safety devices such as fuses, motor protectors, systems against accidental restart after a power failure. Even the switch, if any, will only start/stop the pump and can in no way replace a suitable circuit breaker. It is therefore the direct responsibility of the installer to connect the pump to the main electrical panel in compliance with the regulations in force in the country of use.*

## 6 - INTENDED USE

### 6.1 - PRELIMINARY CHECKS AND START-UP

After ensuring there is diesel fuel in the suction tank, that all pipes and components on the hydraulic line are in good condition and properly sealed, and the nozzle is closed, the pump can be started. After inserting the nozzle into the filling hole, switch the pump on, gradually release the nozzle lever and start transferring the diesel fuel. When you have finished filling, close the nozzle and switch the pump off. If you are using an automatic nozzle, it will automatically close as soon as you have finished filling.

**⚠ WARNINGS!** *Never leave the filling position to prevent accidental diesel fuel spillage. Do not start the pump before having connected the suction and discharge pipes. Do not start or stop the pump by inserting or unplugging any plugs. Do not touch any switches with wet hands. Avoid direct contact of the diesel fuel with skin or eyes as it may cause harm. Use of goggles and gloves is recommended. The single-phase motors are fitted with motor protectors and systems against accidental restart. In the event of a power failure, remember to switch the pump off and unplug it before restoring it. Work cycles that are continuous or in extreme*

*conditions for the pump can cause the motor temperature to rise and its subsequent shutdown by the circuit breaker. Switch the pump off and wait for it to cool down before resuming work. The circuit breaker automatically switches off when the motor has cooled sufficiently.*

**!** *CAUTION! During the first priming phase, the pump must be able to discharge the air, initially present in the suction pipe and in the pump, from the discharge line. To facilitate this procedure, make sure the nozzle or the discharge outlet is kept open. If an automatic nozzle is installed on the discharge line, it is recommended to temporarily disassemble the nozzle to facilitate pump suction during first start-up.*

## **6.2 - INTENDED USE**

- If hoses are used, make sure the ends are properly connected to the tanks. Firmly hold the end of the discharge pipe to prevent accidental spillage.
- Before starting the pump, make sure the discharge valve or the nozzle is closed.
- When you are ready, switch the pump on. The pump can remain in bypass (internal circulation if the discharge is closed) only for brief periods.
- With the pump on and in bypass, open the discharge valve or nozzle holding it firmly.
- When you have finished dispensing, close the valve or nozzle and switch the pump off.

**!** *CAUTION! Operation of the pump with discharge closed is allowed only for brief periods (max 1-2 minutes). Make sure the pump is switched off after use.*

If there is a power failure:

1. Close the discharge valve or nozzle
2. Put the end of the discharge pipe into its housing on the tank
3. Switch the pump OFF

When the power has returned, restart the unit as described at the beginning of the section.

## **6.3 - NOISE LEVEL**

Under normal operating conditions the noise emitted by all models does not exceed 70 dB at a distance of 1 metre from the electric pump.

## **6.4 - COMPATIBILITY IN AN ELECTROMAGNETIC ENVIRONMENT**

The machine is designed to operate correctly in an industrial electromagnetic environment, and staying within the Emission and Immunity limits laid down in the following Harmonised Standards:

**IEC EN 61000-6-2**            Electromagnetic compatibility (EMC) - Generic standards  
Immunity for industrial environments

**IEC EN 61000-6-4**            Electromagnetic compatibility (EMC) - Generic standards  
Emission standard for industrial environments

## 7 - TROUBLESHOOTING

PROBLEM	POSSIBLE CAUSE	CORRECTIVE ACTION
THE PUMP DOES NOT START UP	Power failure	Check the electrical connections and the safety devices
	The circuit breaker has tripped	Use the electric pump in the recommended operating conditions and according to its intended use (chap. 2 - chap. 5)
	Impeller blocked	Make sure there are no obstructions in the pump body or along the suction and discharge lines
	Defective motor	Contact the dealer (fault code M1)
LOW OR NO FLOW RATE	Low level of liquid in the tank	Fill the tank
	Filter dirty or clogged	Clean or replace the filter
	Foot valve dirty or clogged	Clean or replace the foot valve
	Pipe or dispensing nozzle damaged	Replace the damaged components
	Excessive negative pressure to the suction line	Make sure there are no leaks or restrictions on the suction part (recommended pipes chap. 5.2)
	High pressure drops in the circuit	Change the hydraulic discharge configuration
	Bypass valve open or blocked	Check the condition of the valve and clean or replace it if necessary
	Vanes blocked	Check and clean the vanes and their housings
	Excessive wear of the vanes or impeller	Replace the worn components
	Leaks from the gaskets	Make sure the gaskets are properly tightened and not worn
	Incorrect power supply voltage	Power the pump as specified on the rating plate
	Defective motor	Contact the dealer (fault code M2)
PUMP IS VERY NOISY	Cavitation	Reduce the negative suction pressure
		Make sure there are no leaks or restrictions on the suction part (recommended pipes chap. 5.2)
	Air in the hydraulic circuit	Make sure there are no suction leaks
Dispense to bleed the air from the circuit		
LIQUID LEAK	Clamps loosened	Make sure all clamps are properly tightened
	Gaskets worn	Replace the worn gaskets
	Non-compatible liquids used	Check compatibility of the fluid used (chap. 3.3)
	Shaft seal ring dirty or damaged	Contact the dealer (fault code A1)

## 8 - MAINTENANCE

Maintenance includes inspections, checks and interventions which, to prevent interruptions and breakdowns, systematically keep the machine lubrication status and the parts subject to wear under control. These operations, although simple, must be carried out by Qualified Personnel.



The machine is designed to minimise routine maintenance. It is the operator's responsibility to assess the status and its suitability for use. We recommend stopping the operations and performing maintenance every time operation is not perfect. This will always allow maximum efficiency.

Always use the appropriate PPE (Personal Protective Equipment):

**!** *CAUTION! Make sure the pump is disconnected from the power supply and is not in operation before carrying out any maintenance.*



Safety footwear



Protective clothing



Protective gloves



Safety goggles

**!** *WARNING! Failure to comply with these requirements will release the manufacturer from any liability resulting from the effects of the Warranty.*

MAINTENANCE	FREQUENCY	MACHINE STATUS	SYMBOL
Make sure the pipes and couplings are properly connected	Every month	Isolation for Maintenance purposes	
Check/clean pipes and fittings	Every 12 months	Isolation for Maintenance purposes	
Check/clean filter and fittings	Every month	Isolation for Maintenance purposes	
Check/clean pump body	Every month	Isolation for Maintenance purposes	

## 9 - DEMOLITION AND DISPOSAL

If the electric pump is to be scrapped, its parts are to be given to companies specialised in disposing of and recycling industrial waste, as shown on the table below:

### PARTS TO BE DISPOSED OF

### DISPOSAL METHOD

PACKAGING

The packaging consists of biodegradable cardboard which can be sent to companies for normal pulp recycling.

METAL PARTS

The metal parts, whether painted or stainless steel, are usually recycled by companies specialised in the scrap metal industry.

ELECTRICAL AND ELECTRONIC COMPONENTS

These must be disposed of by companies specialised in disposing of electronic components, in compliance with the requirements of Directive 2002/96/EC (see Directive text below).

PARTS OF A DIFFERENT NATURE

Other parts of the system in which the electric pump is installed, such as pipes, rubber gaskets, plastic parts and wiring, are to be given to companies specialised in disposing of industrial waste.



### APPLICABLE REGULATIONS FOR CUSTOMERS IN THE EUROPEAN UNION

The European Directive 2002/96/EC states that the equipment bearing this symbol on the product and/or on the packaging is not to be disposed of with unsorted municipal waste. The symbol indicates that this product must not be disposed of with normal household waste. It is the responsibility of the owner to dispose of these products and the other electrical and electronic equipment through specific collection facilities appointed by the government or by local authorities.

## 10 - WARRANTY

The warranty provided by the manufacturer Adam Pumps Spa covers the product for 2 years from the date of production. Adam Pumps Spa (manufacturer) provides its customers with:

- a warranty that covers problems resulting from production and conformity defects in the purchased products
- the warranty period starts from the date indicated on the CE label which indicates the date of manufacture. A label indicating the date of manufacture will be applied to those products which are not provided with a CE label. Therefore, the warranty period will start from that date;
- the warranty will become immediately null and void should the data of manufacture be illegible, for any reason, unless Adam Pumps Spa is responsible for this;
- the warranty covers repairs or replacement of the product, in the event it cannot be repaired
- repair operations can be carried out only by Adam Pumps or by Adam Pumps' authorised centres;
- the warranty will not be valid in the event the product is tampered with by unauthorised persons, bodies, and/or companies;
- any warranty request is subject to approval by Adam Pumps. The goods can be returned only if provided with an authorisation code. Upon request, Adam Pumps will provide this code which will invoke the warranty for the product to be repaired or replaced unless otherwise agreed with Adam Pumps, the returned goods must be sent via transport pre-paid by who has invoked the warranty to Adam Pumps Spa;
- goods returned without authorisation and/or with transport not paid can be rejected;

The warranty will not be applied in the following cases:

- Failure to use or install the product according to Adam Pumps' instructions
- The product has been used with unauthorised fluids.
- The product has been modified or tampered with
- The product is used in an area with power supply defects (voltage changes, current phase shift, etc.)
- The product is used without the supplied suction filter (inside or outside the pump).
- Immediately excluded from the warranty are: adhesive labels, plastic and metal casing, keyboards and masks, components subject to wear such as blades, impellers, graphite brushes (where present in the motors), seals and gaskets in general.

## 11 - TECHNICAL SUPPORT

The Manufacturer is always available for any information required on installation, operation or maintenance of the machine. The Customer should ask the questions clearly, with reference made to this Manual and to the instructions listed.

## 12 - ATTACHMENTS

### 12.1 EXPLODED VIEWS AND SPARE PARTS LIST

## PA1 70A

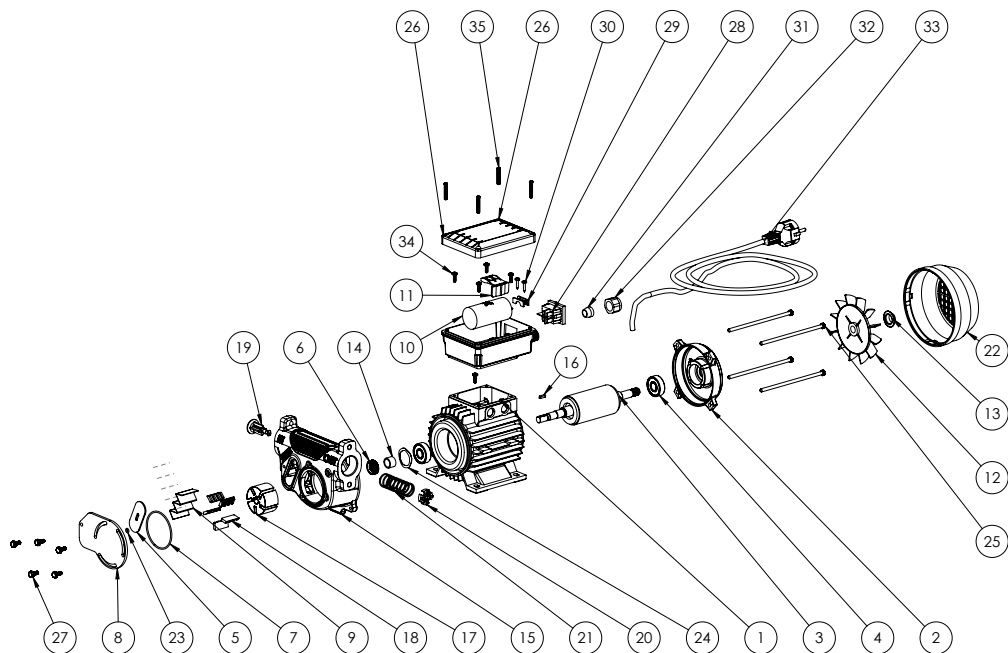

POS. CODE	DESCRIPTION	QTY	POS. CODE	DESCRIPTION	QTY		
1	ME033	Wound stator MEC 63	1	19	71000520	by pass valve	1
2	ME032	Shield worked MEC 63	1	20	71000521	plate	1
3	ME034	Engine shaft MEC 63	1	21	16001005	by pass spring 60-80-100	1
4	101001600000	radial ball bearing 6201 2RS	2	22	140250500000	fan cover mec 63	1
5	OR037	die-cut plisset filter gasket	1	23	11010040200	O-Ring 2015 NBR	1
6	OR038	Seal 10197 TCV inox spring 10X19X7	1	24	845000000000	compensation ring Øe 31,4 Øi 24,2	1
7	OR039	O-RING NBR70 57x2	1	25	610046000000	tie rod m5 x 125	4
8	PA018	swivel locking plate	1	26	PA023	capacitor box	1
9	PA019	inox filter16x49	1	27	VT046	screw te m5x12 flanged uni5541	5
10	PA020	Capacitor 12.5 µF 450 V	1	28	EL013	Switch 22X30 + Cap	1
11	PA024	bracket block capacitor	1	29	140250300000	cable lock	1
12	PA025	fan MEC 63	1	30	VT004	screw TC Croce Ø3,5x16 UNI 6954	2
13	PA026	fan mec 63 ring ø12	1	31	17001011	cable gland rubber	1
14	PA029	cylindrical spacer ø12,4X16 H11	1	32	17001012	cable gland ring nut	1
15	CP009X	body pump pa 70l x-treme	1	33	190200000000	black cable with schuko plug 230V	1
16	PA021	pin 3x3x15 UNI 6604-B	1	34	VT037	screw TC Croce M4x6 Tril. UNI 8112	5
17	61000003	impeller Ø45	1	35	VT049	screw tc 3x8 bn13577 wn1412	4
18	71000522	small vane	5				

PA2 80

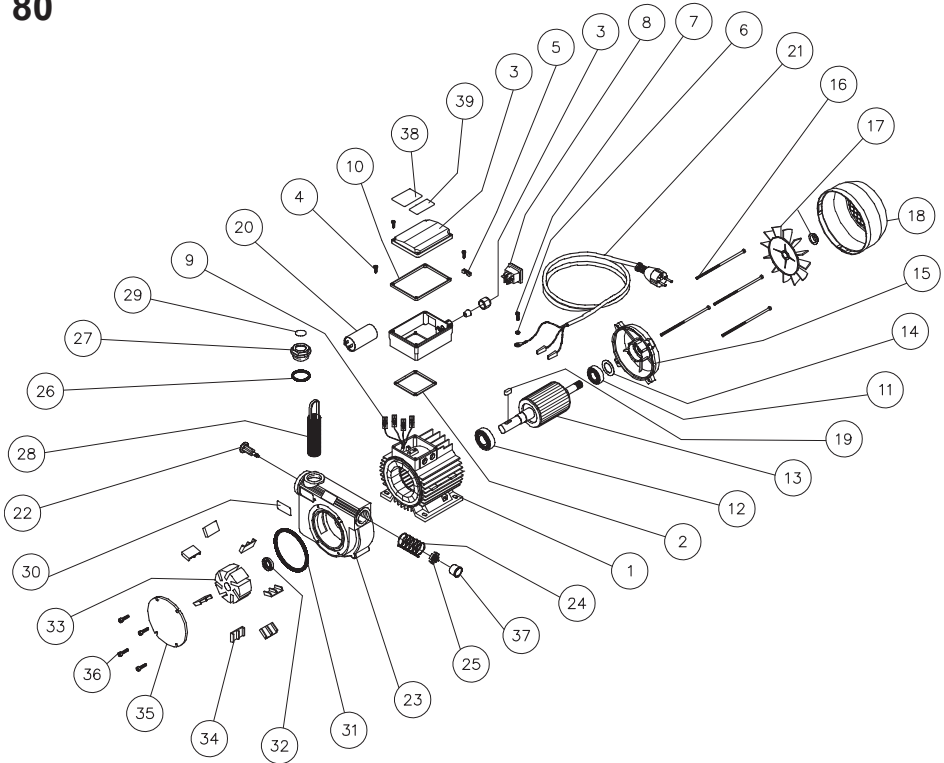

POS.	DESCRIPTION	CODE	QTY	POS.	DESCRIPTION	CODE	QTY
1	wound stator mec 71	6410000000	1	21	black power cable	19020000000	1
2	gasket fv 63/71-2	10501000000	1	22	bypass valve	71000520	1
3	capacitor holder	140250100000	1	23	pump body 80l 1" bsp/g	71000060	1
4	self-t. socket head cap screw ø3.5x16 vt004		10	24	bypass spring	16001005	1
5	cable lock	140250300000	1	25	plate	71000521	1
6	grower washer ø4 znb	80301400000	1	26	or 3118 nbr	18001008	1
7	socket head cap screw M4x8	82301410100	1	27	cap 1"	17001094	1
8	switch 22 x 30	190050210000	1	28	large stainless steel filter	41410000	1
9	Faston cover 6.3	190110000000	6	29	"filter" plate	71000587	1
10	gasket fkl 71	10502000000	1	30	"filter cleaning" plate	71000546	1
11	bearing 6202 2rs	101001700000	1	31	or 85 x 3 nbr	18001022	1
12	bearing 6204 2rs	101001880000	1	32	sealing ring 20307	12001015020	1
13	shaft mec71	62901700000	1	33	impeller ø72	61000010	1
14	compensation ring	84505000000	1	34	large vane	71000569	7
15	processed shield mec 71	15502600000x	1	35	large disc	71000063	1
16	tie-rod m5 x 135 znb	6100450000z	4	36	socket head screw M5x16	13001007	4
17	fan mec 71 + ring ø14	140260400000	1	37	thread protection cap ø31	163013500000	2
18	fan cover mec 71	140260500000	1	38	"danger" label	71000653	1
19	key 6 x 6 x 20	90505050000	1	39	"ce" label	-	1
20	capacitor	190061000000	1				

## PA2 100

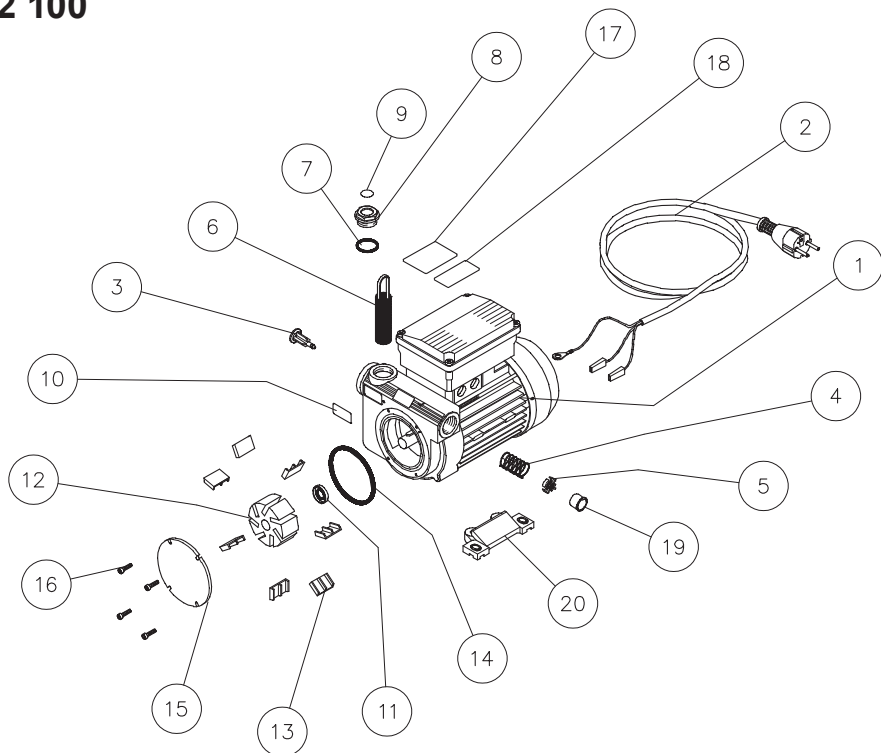

POS.	DESCRIPTION	CODE	QTY
1	motor 230v mec 80	71009018	1
2	black power cable	190200000000	1
3	bypass valve	71000520	1
4	bypass spring	16001005	1
5	plate	71000521	1
6	large stainless steel filter	41410000	1
7	or 3118 nbr	18001008	1
8	cap 1"	17001094	1
9	"filter" plate	71000587	1
10	"filter cleaning" plate	71000546	1
11	sealing ring 20307	12001015020	1
12	impeller $\varnothing 72$	61000010	1
13	large vane	71000569	7
14	or 85 x 3 nbr	18001022	1
15	large disc	71000063	1
16	socket head screw m5 x 16 znb.	13001007	4
17	"danger" label	71000653	1
18	"ce" label	220000000000	1
19	thread protection cap $\varnothing 31$	163013500000	2
20	motor foot mec 80	240023mec80	2

# PA3 150

**NOTE PA3 150L:**

do not do under  
5-second motor restarts

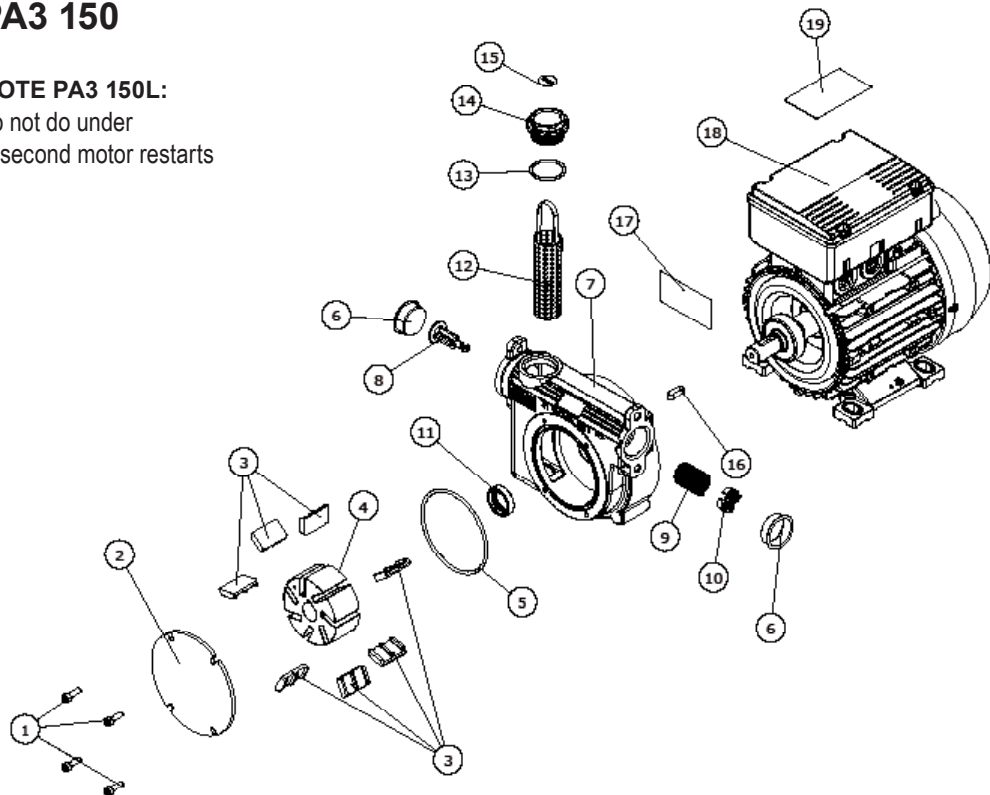

POS.	DESCRIPTION	CODE	QTY
1	hex socket head cap screw M5X16 ISO 4762	13001007	4
2	pump cover 80-100 L.	71000063	1
3	large vane	71000569	6
4	impeller ø72	61000010	1
5	O-Ring 85X3 NBR	18001022	1
6	thread protection cap ø31	163013500000	2
7	pump body 150l	71000061	1
8	bypass valve	71000520	1
9	bypass spring	16001005	1
10	plate	71000521	1
11	sealing ring 20x30x7 SNBR	12001015020	1
12	large stainless steel filter	41410000	1
13	O-Ring 3118 NBR	18001008	1
14	cap 1"	17001094	1
15	"filter" label	71000587	1
16	key 6x6x20 UNI 6604-A	90505050000	1
17	ce label	-	1
18	motor 150l	me002	1
19	"danger" label	71000653	1

## 12.2 WIRING DIAGRAMS

### PA1 70 - PA2 80 - PA2 100

- S1 ON-OFF switch
- M Motor
- T Circuit Breaker
- C Capacitor

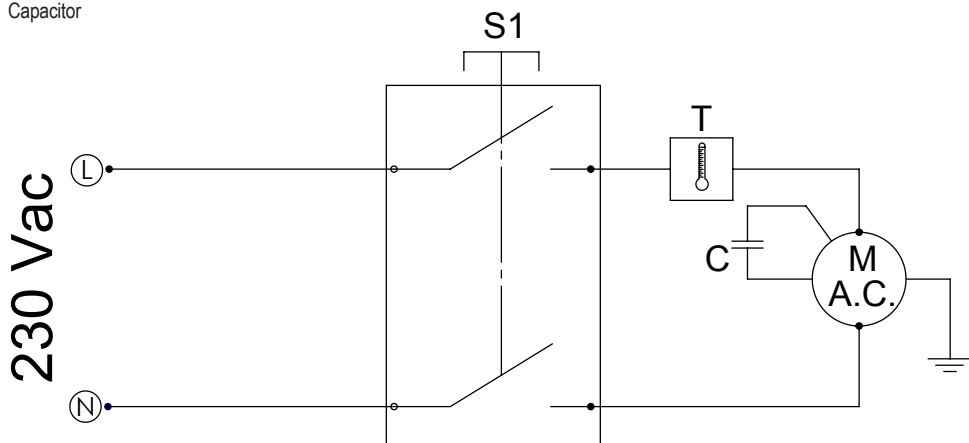

### PA3 150

- S1 ON-OFF switch
- M Motor
- T Circuit Breaker
- C1 Phase capacitor
- Cs Start capacitor

