

12 / 24 Volt DC Transfer Pump



Applies to the following models **ONLY**:

12PA.K1CE **24PA.K1CE**

Please read carefully **BEFORE** commencing installation.

Registered Office: HYTEK (GB) LIMITED,
Delta House, Green Street, Elsenham, Bishop's Stortford,
CM22 6DS UK.

Registered in England No. 1915382

Tel: +44 (0) 1279 815 600

Email: info@hytekgb.com

IMPORTANT WARNING NOTES

Failure to comply with any of the following will invalidate the pump warranty.

1. This pump **MUST NOT** be used to dispense petrol or other flammable liquids.
2. It must not be sited adjacent to a petrol dispenser or in any other hazardous zone.
3. Assembly of this equipment and its associated pipe work and fittings should only be carried out by qualified fuel installation engineers.
4. The pump must only be operated when the pump chamber is full of liquid. It must not be run "Dry".
5. The pump must only be operated with the supplied suction strainer fitted to the end of the suction hose in accordance with the assembly instructions below.
6. Maximum run time 15 mins for 24V pumps, 30 mins for 12v pumps.
7. The pump must not be run on bypass (nozzle closed) for periods exceeding 1 minute.
8. The installation must conform to all relevant electrical and local authority regulations and standards.

ENVIRONMENTAL INFORMATION

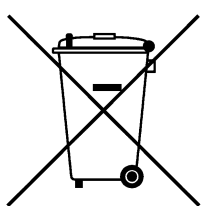

UK Regulation SI 2013 3113 requires that the equipment bearing this symbol on the product and/or its packaging must not be disposed of with unsorted municipal waste. The symbol indicates that this product must be disposed of separately from regular household waste streams. It is your responsibility to dispose of this and other electric and electronic equipment via designated collection facilities appointed by the government or local authorities.

PRODUCT DESCRIPTION

The 12PA & 24PA range are designed to pump clean non-flammable liquids such as diesel or gas oil in an outdoor environment using a 12 or 24 volt DC electrical supply.

COMPONENTS

Check you have the following:

DIAGRAM PART No.

12PA.BA/CA, 24PA.BA/CA

1 x 12 or 24VDC Pump	(1)
2 x Hose Tails 3/4"	(2)
1 x Hose Tail 1"	(3)
1 x Foot Valve/Strainer	(4)
1 x PTFE Sealing Tape	(5)

12 & 24 PA.KIT1B/C, 12 & 24 PA.KIT2B/C

1 x 12 or 24VDC Pump	(1)
2 x Hose Tails 3/4"	(2)
2 x Hose Tails 1"	(3)
1 x Foot Valve/Strainer	(4)
1 x PTFE Sealing Tape	(5)
1 x Fuel Delivery Nozzle	(6)
4 x Hose Worm Drive Clips	(7)
1 x 6 Metre x 3/4" Bore Fuel Delivery Hose	(8)

12PA.BF/CF, 24PA.BF/CF

1 x 12 or 24VDC Pump	(1)
1 x Foot Valve/Strainer	(2)

12 & 24 PA.K1B/CM, 12 & 24 PA.K2B/CM

1 x 12 or 24VDC Pump with Meter	(1)
1 x Hose Tails 3/4"	(2)
3 x Hose Tails 1"	(3)
1 x Foot Valve/Strainer	(4)
1 x PTFE Sealing Tape	(5)
1 x Fuel Delivery Nozzle	(6)
4 x Hose Worm Drive Clips	(7)
1 x 6 Metre x 3/4" Bore Fuel Delivery Hose	(8)

12 & 24 PA.K1CE

1 x 12 or 24VDC Pump	(1)
2 x Hose Tails 3/4"	(2)
1 x Foot Valve/Strainer	(4)
1 x PTFE Sealing Tape	(5)
1 x Fuel Delivery Nozzle	(6)
4 x Hose Worm Drive Clips	(7)
1 x 6 Metre x 3/4" Bore Fuel Delivery Hose	(8)

PARTS DIAGRAM

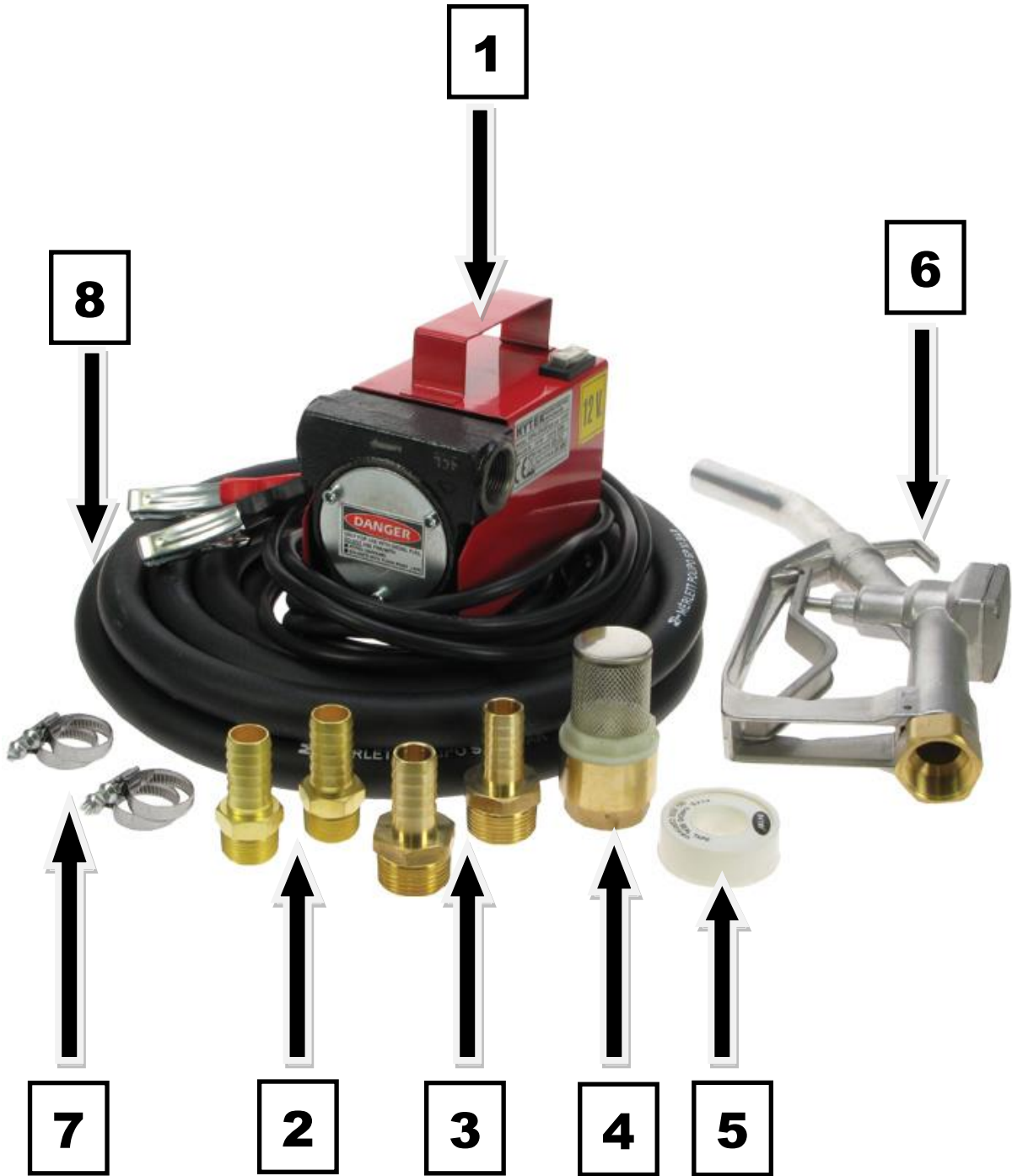

ASSEMBLY

1. If foot valve does not already have a hose tail fit a 1" hose tail (3) to the foot valve (4). Seal threaded joint with PTFE (5).
2. Fit required length of suitable ¾" bore suction hose to the foot valve assembly (4), securing with a worm drive clip (7). For the 12/24 PA.K1CE, 12/24PA.KIT1B/C & 12/24PA.KIT2B/C cut the required length of hose from the 6 metre hose (8) supplied.
3. Fit a hose tail (2) to the pump inlet (the inlet is located on the right side of the pump if you view the pump with the black end facing towards you) using PTFE tape (5) to seal the joint. In turn fit the suction hose, to the inlet hose tail (2) securing with a hose worm drive clip (7).
4. Fit a length of suitable ¾" bore fuel delivery hose to a fuel delivery nozzle (6) with a 1" hose tail fitted (3). For the 12/24 PA.K1CE, 12/24PA.KIT1B/C & 12/24PA.KIT2B/C cut the required length of hose from the 6 metre hose (8) supplied, fit to the nozzle (6) using a hose tail (3) and secure with a worm drive clip (7). Seal the threaded joint with PTFE tape (5).
5. Fit the remaining hose tail (2) to the pump outlet. Use PTFE tape (5) to seal the joint. In turn fit the hose and nozzle assembled in part 5 to the pump outlet hose tail (2), securing with a worm drive clip (7).

OPERATION

1. Ensure the pump is filled with fuel and fully primed.
2. Connect the pump crocodile clips to a suitable 12 or 24-volt DC power supply as follows:

Red Crocodile Clip:	Positive (+)
Black Crocodile Clip:	Negative (-)
3. Fully immerse the end of the suction hose in the fuel to be pumped and place the fuel delivery nozzle in the tank / container to be filled.
4. Switch on pump and dispense fuel.
5. The pump must not be run on bypass (nozzle closed) for periods exceeding 1 minute.

DUTY CYCLE WARNING:

THIS PUMP IS DESIGNED FOR INTERMITTENT USE. DO NOT RUN THIS PUMP CONTINUOUSLY FOR LONGER THAN 30 MINS FOR 12V PUMPS, 15 MINS FOR 24V PUMPS, AS IT MAY DAMAGE THE MOTOR AND VOID THE WARRANTY. ALLOW PUMP TO COOL FOR 15 MINS (24V) 30 MINS (12V) OR TO AMBIENT TEMP BEFORE RESUMING OPERATION.
DUTY CYCLE WILL VARY WITH LOAD AND AMBIENT TEMPERATURE.

BYPASS WARNING:

DO NOT ALLOW THIS PUMP TO RUN ON BYPASS (NOZZLE CLOSED) FOR PERIODS LONGER THAN 1 MINUTE. FAILING TO DO THIS MAY DAMAGE THE PUMP UNIT AND VOID WARRANTY.

COMPONENTS/SPARE PARTS

BARE PUMP – NO RED CASE (12V & 24V)

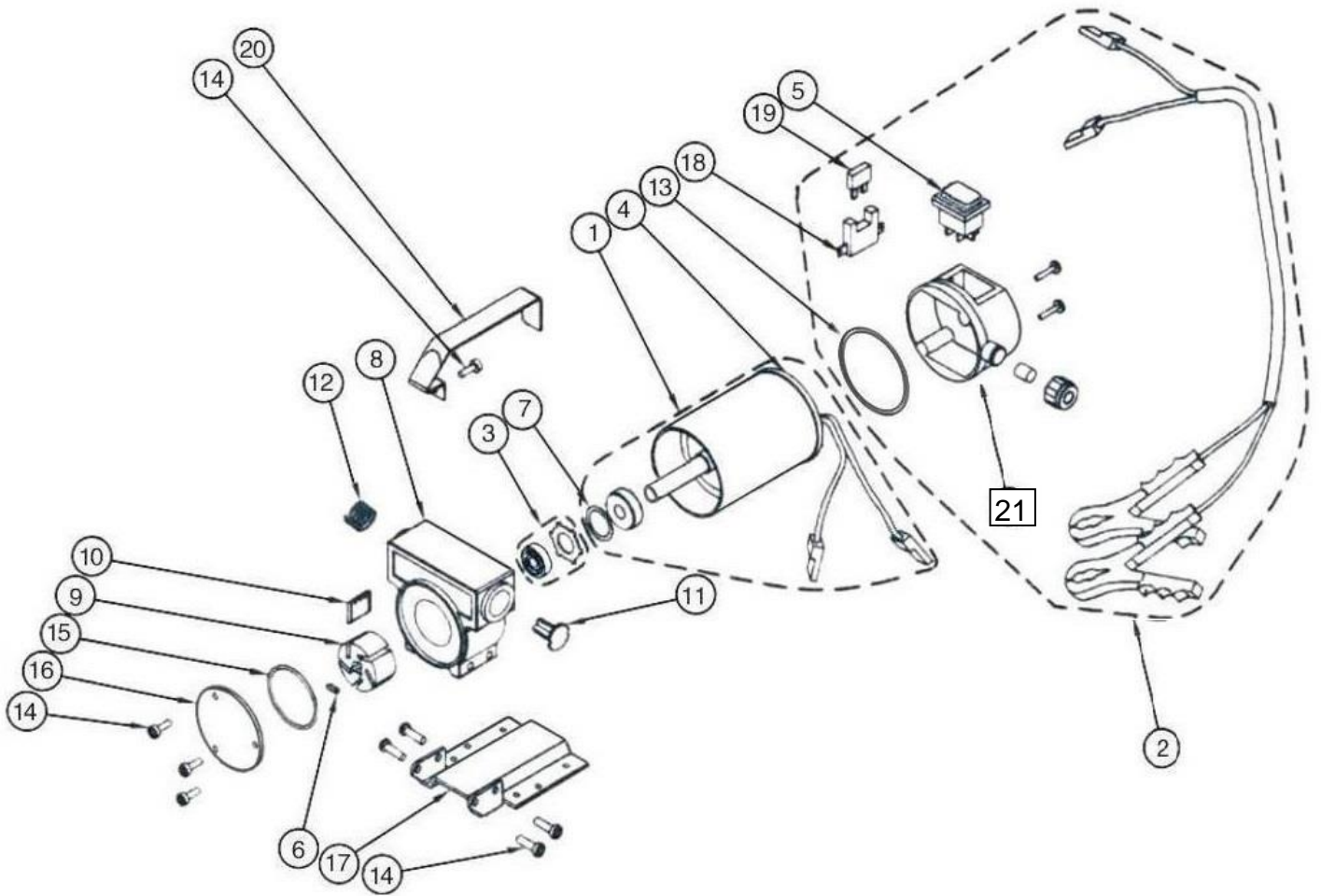

STOCK CODE	DESCRIPTION	DIAGRAM No.	QUANTITY PER PUMP
12PA.1	ROTOR	9	1
12PA.2	VANES	10	5
12PA.4	ON/OFF SWITCH	5	1
12PA.5	ROTOR PLATE	16	1
12PA.6	ROTOR PLATE O-RING	15	1
12PA.7	ROTOR KEY	6	1
12PA.9	POWER LEAD & CROC CLIPS	2	1
12PA.10	SHAFT SEAL	3	1
12PA.11	JUNCTION BOX (NO SWITCH)	21	1
12PA.FUSE	30A BLADE FUSE	19	1
12PA.CABLE	CABLE FOR EXTENDING POWER LEAD	N/A	N/A

All other parts shown available on request.

RED CASED PUMP (12V & 24V)

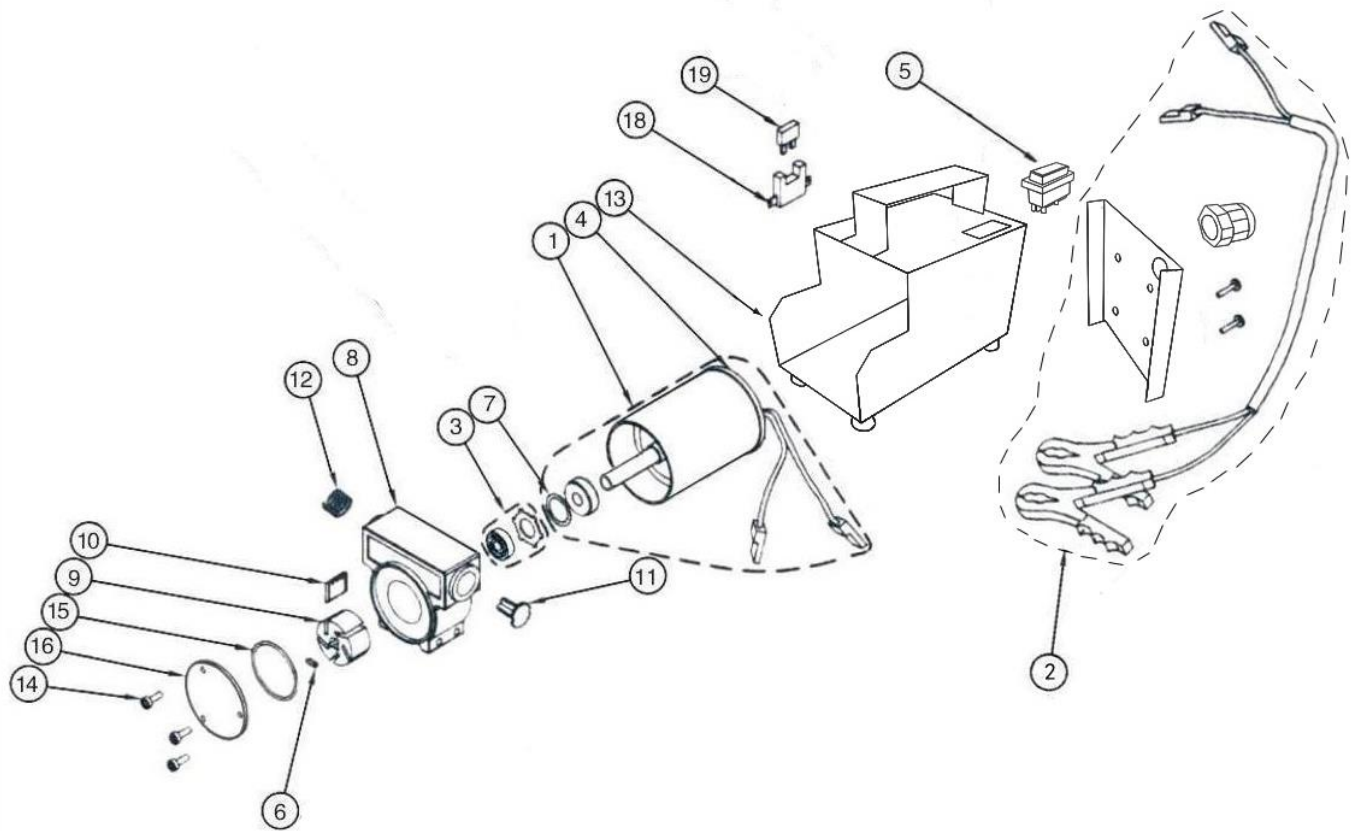

STOCK CODE	DESCRIPTION	DIAGRAM No.	QUANTITY PER PUMP
12PA.1	ROTOR	9	1
12PA.2	VANES	10	5
12PA.3	ON/OFF SWITCH	5	1
12PA.5	ROTOR PLATE	16	1
12PA.6	ROTOR PLATE O-RING	15	1
12PA.7	ROTOR KEY	6	1
12PA.8	RED PUMP CASING	13	1
12PA.9	POWER LEAD & CROC CLIPS	2	1
12PA.10	SHAFT SEAL	3	1
12PA.FUSE	30A BLADE FUSE	19	1
12PA.CABLE	CABLE FOR EXTENDING POWER LEAD	N/A	N/A

All other parts shown available on request.

DECLARATION OF CONFORMITY



Company Name: **Hytek (GB) Ltd**

Address: **Delta House, Green Street.
Elsenham, Bishops Stortford,
Hertfordshire, CM22 6DS, UK**

Date of Issue: **6th June 2017**

Equipment Details: **12PA and 24PA Ranges of Diesel Transfer
Pumps 12 or 24 Volt DC Operated**

Applicable Directives: **2014/30/EU EMC Directive**
& Standards EN 61326-1:2013
Electromagnetic compatibility (EMC) – Group 1,
Class B Eq. (Emissions)
EN 61326-1:2013
Electromagnetic compatibility (EMC) – Industrial
Environment (Immunity)

2014/35/EU Low Voltage Directive

2006/42/EC Machinery Directive

2014/68/EU Pressure Equipment Directive

**2012/19/EU Waste Electrical & Electronic
Equipment Regulations**

**2011/65/EU Restriction of Hazardous
Substances Directive (RoHS2)**

RoHS test report number NB2010060601S2
By Product Technology Service (Ningbo) Co.
6&7F, 59, Huayu Road, Yinzhou District
Ningbo 315192, P.R. China

Declaration Number: **EU044/7**

On behalf of the above named company, I declare under our sole responsibility that, on the date the equipment accompanied by this declaration is placed on the market, the equipment conforms with all technical and regulatory requirements of the above listed directives.

A handwritten signature in black ink that reads "Clive Wellings".

Clive Wellings, Technical Manager

THE INFORMATION CONTAINED IN THIS DOCUMENT IS PROTECTED BY COPYRIGHT © AND PROPERTY LAWS AND IS THE SOLE PROPERTY OF HYTEK (GB) LTD. ANY REPRODUCTION IN PART OR AS A WHOLE WITHOUT THE WRITTEN PERMISSION OF HYTEK (GB) LTD IS PROHIBITED.