

Technical Specifications

| | |
|-----------------------------|--|
| Supply Voltage (D.C.) | 9v DC |
| Battery Type | 6 x AA (1.5V) |
| Installation environment | Pollution Degree 3 |
| | Installation Category II |
| Operating Temperature | -20° C to +50° C |
| Ambient Temperature Storage | -30° C to +60° C |
| Maximum Altitude | 2000 Metres |
| Humidity (Operating) | 5 to 100% RH, Non-condensing |
| Enclosure | |
| Dimensions (L x H x D) | 145 x 242 x 110 (mm) |
| Colour | Light Grey RAL 7035 |
| IP Rating | IP 55 |
| Material | Polycarbonate |
| Sounder | |
| Frequency | 2600 Hz |
| Sound Output @12V | 90 dB |
| Float | |
| Material | Nylon Stem, NBR Float, PVC Cable, S/S clip |
| Specific Gravity | 0.70 |
| Cap Mounting Thread | 1.5" BSP |
| Cable Length | 5 metres |

CTS

Centre Tank Services Ltd, Unit 41, Minworth Industrial Park,
Forge Lane, Minworth, Sutton Coldfield. B76 1AH

Website: www.centretank.com

Tel: **0121 351 4445** Fax: **0121 351 4442**



Instructions

Battery Operated Alarm

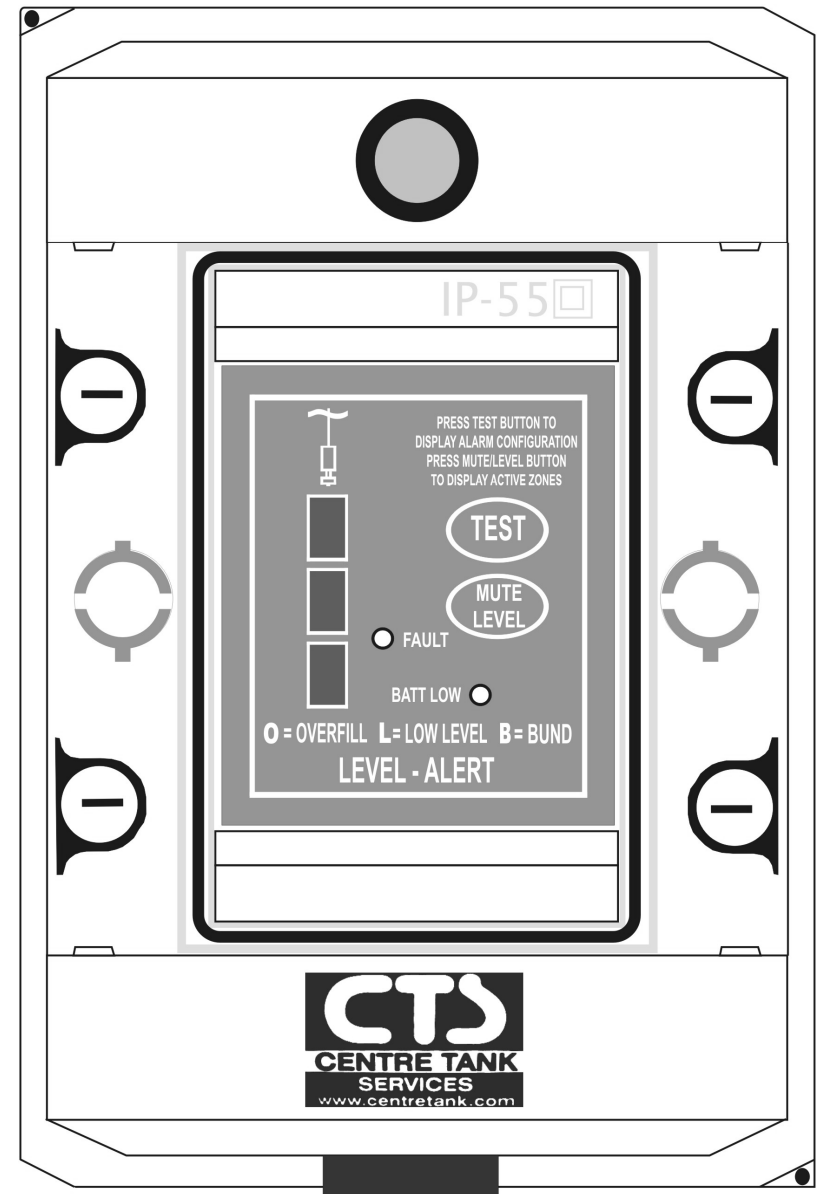

Model: Battery Level - Alert

Index

| Page | Section |
|------|--|
| 2 | Index |
| | Important installation note |
| 3 | Mounting and basic installation |
| 4 | Setting up the alarm |
| | Preliminary checks |
| 5 | Operation |
| | Cable Entry |
| 6–7 | Internal Layout diagrams |
| 8 | Installation details |
| | Fitting the battery |
| | Operating instructions |
| 9 | Probe connections |
| | Common probe connection |
| 10 | Optional extras |
| | Optional relay outputs |
| 11 | Troubleshooting |
| | Alarm conditions |
| 12 | Technical specifications |
| | CTS contact details |

Important Installation Note

This alarm is designed to be installed in exposed locations. **Care must be taken at all times** to ensure that the front panel integral seal is not damaged resulting in water ingress.

Troubleshooting

1. If the **battery low indicator** illuminates or sounder fails to respond, then replace the battery (page 8).
2. If the **alarm activates signalling an overfill condition when the tank is not being filled**, this indicates a probe fault. Check cables and the probe assembly, make sure that the probe is in the correct position and not lying horizontally on the bottom of the tank.
3. If the **probe does not register as supplied**, then repeat sequence shown on page 4 (checking the probe).

Troubleshooting (Alarm Conditions)

1. The unit is designed so that all the zones emit a different sound, enabling you to distinguish the alarm zone without having to visualize it - the top zone is the most rapid (or urgent) on the sounder and the bottom is the least.
2. The Overfill Alarm will only activate when the tank has partially emptied and then been refilled.
3. The Bund Alarm indicates leakage from the tank. The outer cavity should be checked and drained if containing fluid.
4. The Low Level Alarm will only activate when the tank has partially filled and then the fuel drained below the low position.

Zone & Option Switches

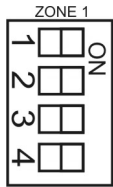

To change the display adjust the Zone switches:

'O' - Switches 1, 2 & 3 ON

'L' - All switches OFF

'B' - All switches ON

The following functions can be set via the option switches:



Switch 3 ON

1 & 2 OFF - Zone 1 only

1 ON, 2 OFF - Zones 1 & 2

1 OFF, 2 ON - Zones 1 & 3

1 & 2 ON - Zone 3 only

4 ON - Battery Unit, LED off when mute pressed

5 ON - Relay ON Zone 3 activated, OFF Zone 1 activated

6 ON - No sounder on Zone 1 (muted)

7 ON - No sounder on Zone 1 or Zone 3 (muted)

8 ON - No sounder on Zone 3 (muted)

Switch 3 OFF

1 OFF - Monitored Probes

1 ON - Standard Probes

2 OFF - Zone 3 N/O

2 ON - Zone 3 N/C

Relay Outputs (Optional)

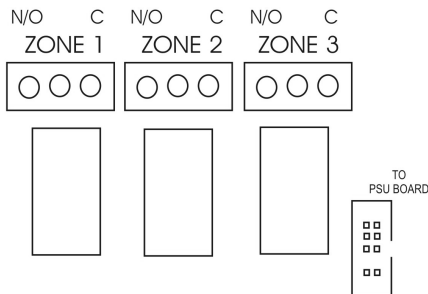

The relay outputs are optional and can be added to the unit at anytime. They allow switching to external equipment when either the High, Bund or Low alert is triggered. For example, a pump is activated in the event

of an overfill. 'C' and 'N/O' are printed on the board for 'Common' and 'Normally Open' - Normally closed (N/C) is not available.

It is important to note the **maximum switched voltage** is **250V AC** and the maximum switched current is **1 Amp**.

Mounting and Basic Installation

1. Remove the Perspex door. Open the door by turning the white tab 90° anticlockwise.
2. Remove the front panel by turning the four plastic screws anticlockwise half a turn.
3. When all four screw slots are vertical the front panel can be lifted free from its base. **(N.B. Do not allow the front panel to hang unsupported on its cables.)**
4. Carefully drill out the four mounting holes in the base.
5. Use the holes as a template to mark the mounting surface.
6. Cable entry grommets must be positioned at the bottom.
7. Screw the base to the mounting surface and insert the four sealing caps into the screw recesses to prevent water ingress. **(N.B. When mounting ensure the base is flat and not distorted as this may result in water ingress.)**
8. Pass the sensor probe cable through the grommet and connect to the probe screw terminal. Repeat the procedure for the second probe (see pages 5 & 9 for more detail.)
9. Fit the 6 x AA (1.5V size) batteries taking care to observe polarity (see page 8 for more detail.)
10. Refit the front panel and door, ensuring that all integral seals are undamaged.

Setting Up The Alarm

Preliminary Checks

Now the alarm has been successfully mounted it is worth doing a few preliminary checks to ensure that the installation will run smoothly. It is particularly important to check the probe as an error found after installation is much more time-consuming.

Checking the Batteries

Press the 'test' button for 2 seconds to ensure the alarm is operational. If no zones are active all lights and the sounder will stop when the button is released.

Checking the probe

Before installing the probe sensors in the tank, manually move the float.

On the Overfill and Bund probes the alarm should sound and the correct lamp illuminate when the float is moved to the top of its shaft.

The Low level probe should sound when the float is positioned at the bottom of the shaft.

If on the Overfill or Bund the alarm sounds when the float moves to the bottom of the shaft or if the Low Level float sounds at the top of the shaft then remove the float by taking off the cir-clip (see diagram). Next rotate the float through 180°, push it back onto the shaft and reinstate the cir-clip.

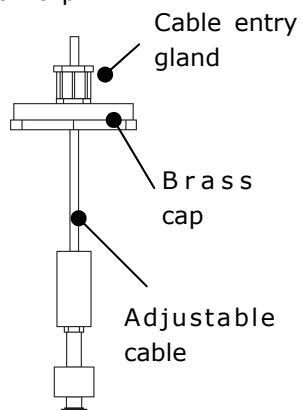
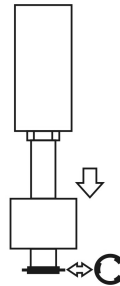

The position of the float can be adjusted to the required height by loosening the cable entry gland on the brass cap.

The cap can then be moved up or down the cable until the required height is achieved (see page 9: 'Probe connections' for more detail on positioning the probes in the tanks).

Retighten the cable entry gland and secure the cap to the tank.

Installation Diagrams

Probe Connections

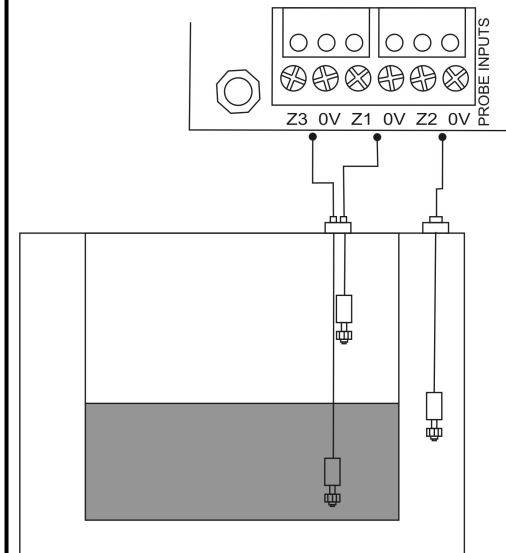

There are six probe connections, which are located as shown here. The probe wired to the 'High' connection is positioned topmost in the tank, and is used to alert that an overfill has occurred. Whereas the probe in the 'Low' connection should be placed near the bottom of the tank, to indicate a low level. The 'Bund' probe is between the two tank 'skins' and is a precaution so situations such as leakage and overflow can quickly be identified.

Common Probe Connection

Typical system setting:

Zone 1 - Overfill Probe

Zone 2 - Bund Probe

Zone 3 - Low-level Probe

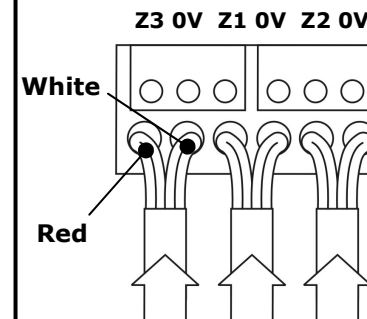

You will notice that in the probe cable there are two wires, one red and one white. The red wire should be connected to the Z(x) terminal and the white wire to the corresponding 0V terminal. The colour is actually irrelevant but it is suggested for simplicity all wires to the '0V' connections are kept the same. For Zone set-up see page 10.

Battery Installation / Operation

Fitting The Battery

The unit is supplied with 6 x AA (1.5v) alkaline batteries, these can be found loose inside the cardboard box, the battery holder is mounted in the base of the enclosure.

Insert 3 x AA batteries in each battery holder making sure the polarity is correct (as per diagram in base of battery holder).

When the unit requires a change of batteries it will emit a single 'bleep' every 2 minutes (very similar to a battery smoke alarm). To test the batteries press and hold the "mute/level" button, if the batteries are low the "Batt Low" and "Fault" lamps will illuminate.

Always replace all the batteries with alkaline cells when required.

Operation

To test press and hold the 'test' button, all zones and large LED will illuminate and the sounder will activate, when the 'test' button is released any active zones will remain illuminated and the sounder will continue to pulse. The 'mute/level' button will clear the sounder, the zone will extinguish after 5 seconds.

To review any active zones press the 'mute/level' button, it will display the active zone for 5 seconds before extinguishing.

To review any faults press and hold the 'mute/level' button, the unit will display the fault LED as well as the faulty zone.

Setting Up The Alarm

Operation

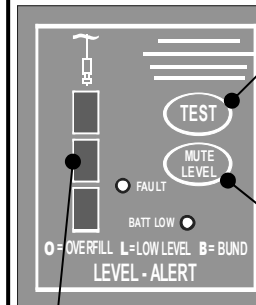

To test the alarm press and hold the 'test' button, whilst the button is pressed all the configured zones, fault, red lamp and sounder will activate. If no zones are active all lights and the sounder will stop when the button is released.

To mute an active alarm press the 'mute/level' button, the strobe and the sounder will stop but the active zone will remain illuminated for 5 seconds or until the zone is cleared. To display active zones press the 'mute/level' button.

The 3 displays can be configured as any of the follows: Overfill 'O', Bund 'L' or Low-Level 'L'. The alarm configuration is displayed when the test button is pressed and held, to change settings see page 10.

Periodically, and specifically before each filling to ensure unit has power and is operating correctly press and hold the 'test' button, all zones and the large red lamp should illuminate and the sounder should activate.

Cable Entry

If the cable entry point is not used, remove gland and seal hole with blanking cap supplied.

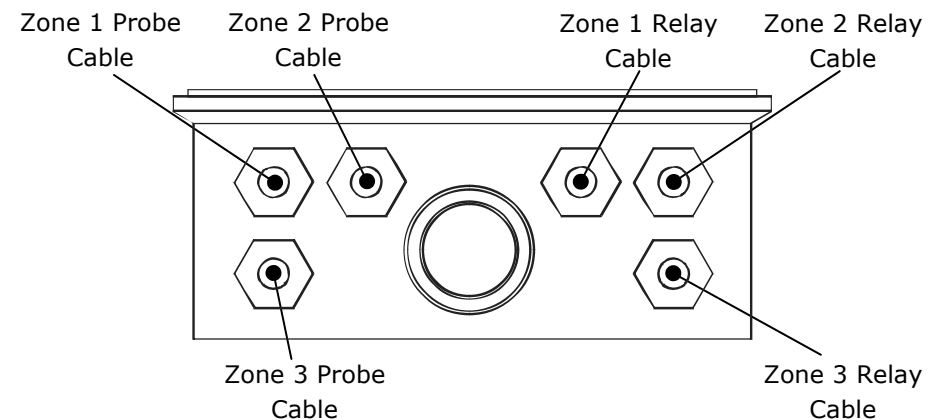

Internal Layout Diagram

Battery Board

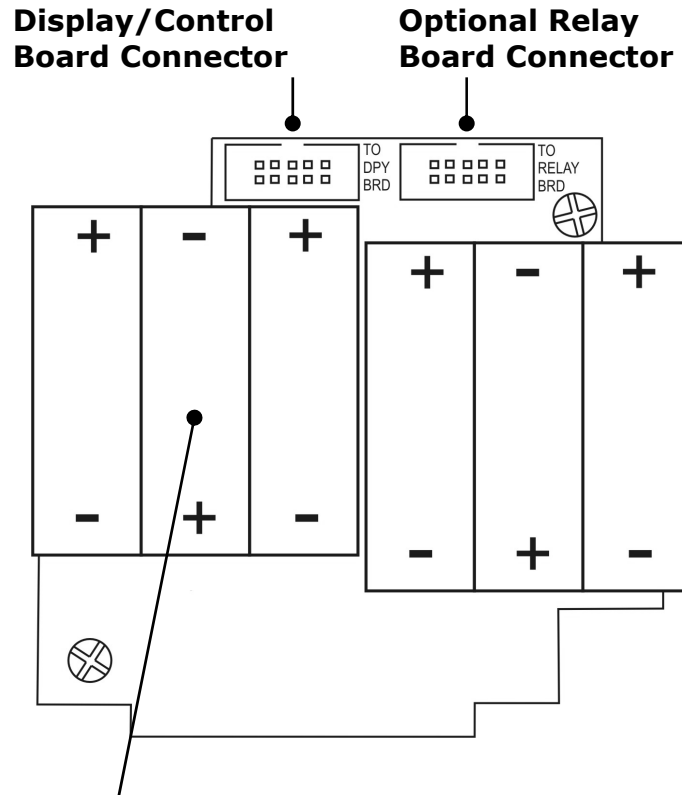

6 x AA Alkaline Batteries
(Make sure polarity is correct)

For more detail please see the following pages:

Battery Fitting: page 8, **Optional Relays:** page 10

Internal Layout Diagram

Display / Control Board

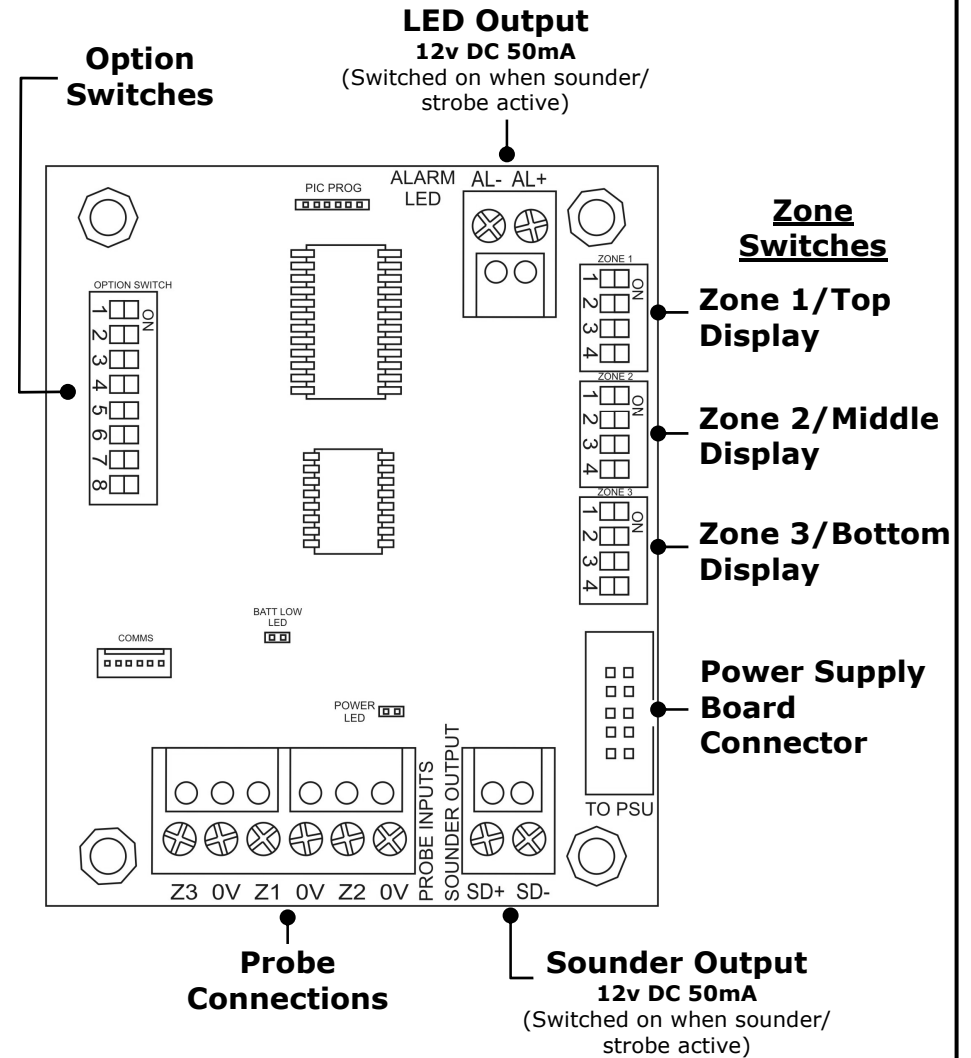

Probe Connections

Sounder Output
12v DC 50mA
(Switched on when sounder/
strobe active)

Zone Switches

Zone 1/Top Display

Zone 2/Middle Display

Zone 3/Bottom Display

Power Supply Board Connector

LED Output
12v DC 50mA
(Switched on when sounder/
strobe active)

Option Switches

For more detail please see the following pages:

Probe Connections: page 9,

Option & Zone Switches: page 10