



AUTHOR: JERRY SCANNELL
APPROVED BY: JS / SW
REV NO: R1.0
REV DATE: 05/10/2018

Tank Specification

Length: 2400 mm
Width: 1700 mm
Height: 1450 mm

Product Mass: 185 kg

Capacity Brimful: 2471 litres
Capacity Nominal: 2348 litres

Material Tank: MDPE

Approval Number: 0654070502 (OFTEC)

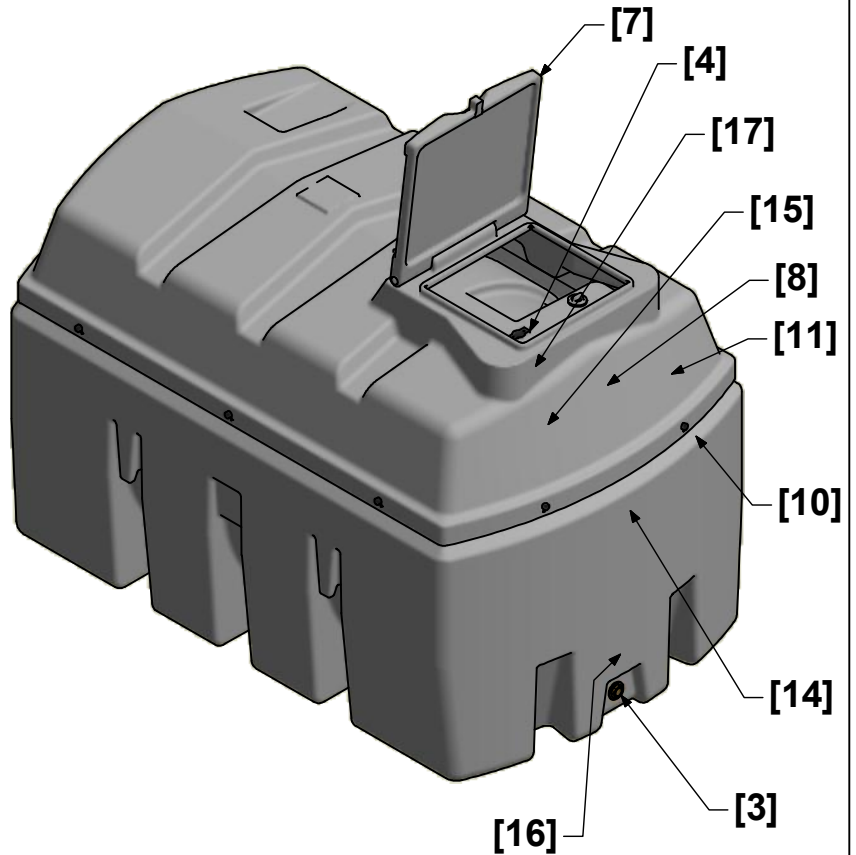

Equipment

1. 5" (~125mm) Inspection Lid - Lockable
2. 2" BSP (~50mm) Offset Fill Connection - Lockable
3. 1" BSP (~25mm) Bottom Outlet
4. Blanking Cap for Contents Gauge and Bund Alarm
5. 2" BSP (~50mm) Vent
6. Dip Stick
7. Spill Container Door - Lockable
8. Product Label
9. Tank Serial Number Stamp
10. Bund Serial Number Stamp
11. Installation Instruction
12. Overfill Prevention - Socket
13. Overfill Prevention - Probe
14. Carbery Graphic
15. CE Label
16. Left Hand Thread Label
17. Handle With Care Label

Options

18. BTGR01350R-105 [Apollo HG]

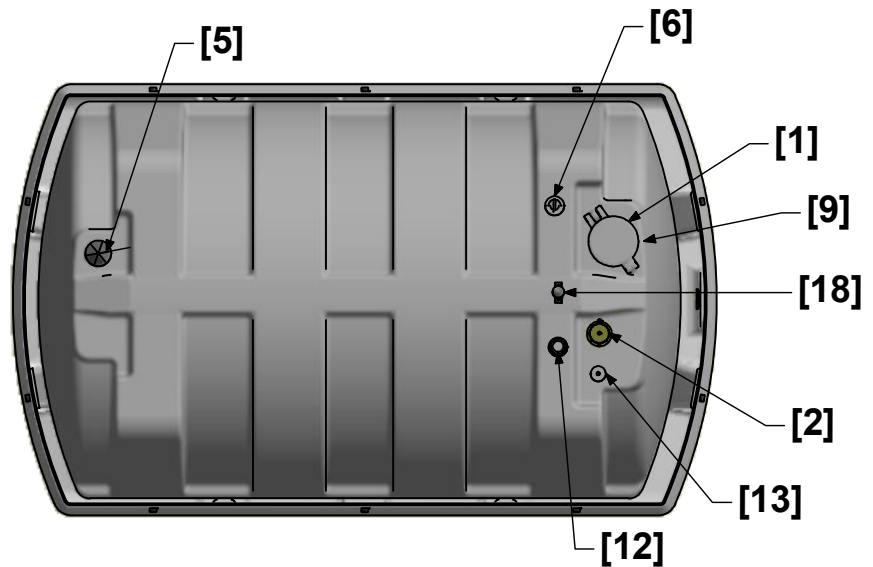

Installation & Siting Guidelines

Carbery Tanks must only be installed and commissioned by a suitably competent person in accordance with supplied instructions and all prevailing statutory requirements.

Please Consult the Installation, Operation and Maintenance Manual for further Information.

Certification

All Carbery Plastics LTD tanks are certified to EN13341.