



**Tank Specification**

Length: 2020 mm  
Width: 1270 mm  
Height: 1200 mm

Product Mass: 112 kg

Capacity Brimful: 1396 litres  
Capacity Nominal: 1326 litres

Material Tank: MDPE

Approval Number: 0654070502 (OFTEC)

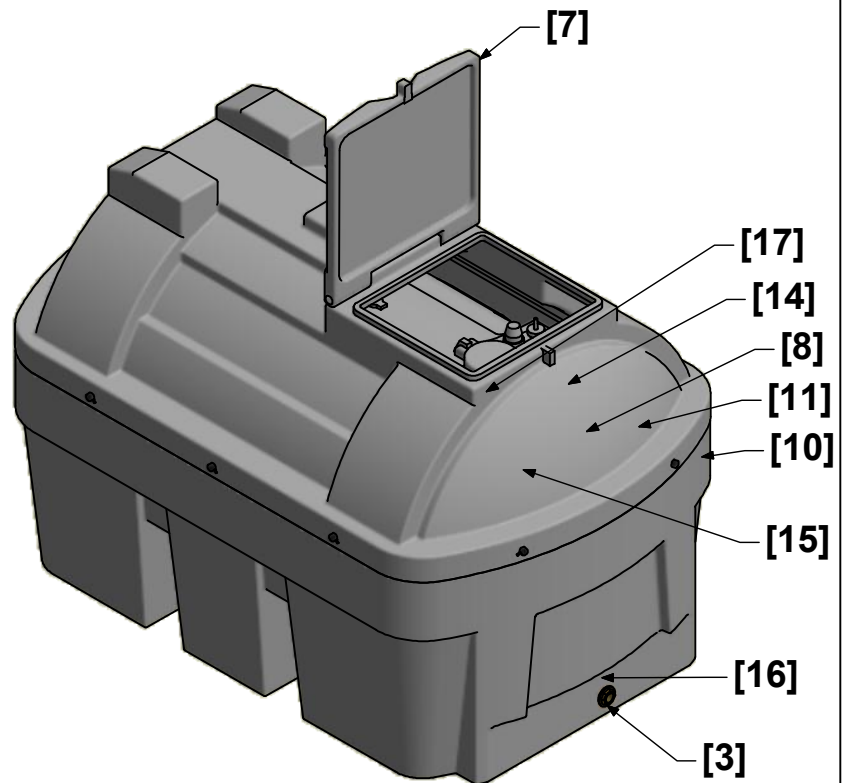

**Equipment**

1. 5" (~125mm) Inspection Lid - Lockable
2. 2" BSP (~50mm) Offset Fill Connection - Lockable
3. 1" BSP (~25mm) Bottom Outlet
4. Blanking Cap for Contents Gauge and Bund Alarm
5. 2" BSP (~50mm) Vent
6. Dip Stick
7. Spill Container Door - Lockable
8. Product Label
9. Tank Serial Number Stamp
10. Bund Serial Number Stamp
11. Installation Instruction
12. Overfill Prevention - Socket
13. Overfill Prevention - Probe
14. Carbery Graphic
15. CE Label
16. Left Hand Thread Label
17. Handle With Care Label

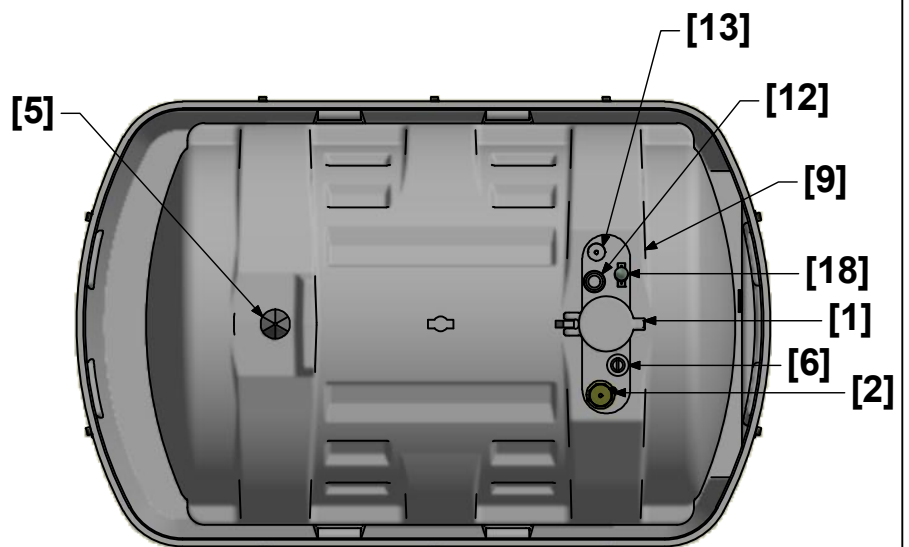

**Options**

18. BTGR01350R-105 [Apollo HG]

**Installation & Siting Guidelines**

Carbery Tanks must only be installed and commissioned by a suitably competent person in accordance with supplied instructions and all prevailing statutory requirements.

Please Consult the Installation, Operation and Maintenance Manual for further Information.

**Certification**

All Carbery Plastics LTD tanks are certified to EN13341.