

Falcon

solar light 202



ZERO *Fuel*
Noise
Emissions
Maintenance

Falcon

solar light 202

Model - FSL-202



Specification

| | |
|-----------------------------|-------------------------|
| Brand | Falcon |
| Name | Solar Light Tower |
| Model | FSL-202 |
| Material | Steel Q235 |
| Powder | Outdoor Type |
| Transport Dimension (LxWxH) | 2200 x 1600 x 2200 (mm) |
| Operate Dimension (LxWxH) | 3200 x 3400 x 9000 (mm) |
| Weight | 1300kg |
| System Voltage | DC48V |

Solar System

| | |
|---------------|---|
| Solar Panel | 3 x 435W Monocrystalline Silicon 108pcs |
| Voltage | DC39V |
| Charging Time | 6.6 hours |

Light System

| | |
|------------------|-------------------------------------|
| LED flood light | 4 x 100W outdoor waterproof 60000lm |
| Protection Class | IP65 |
| Efficiency | 150Lm/W |
| Voltage | DC48V |
| Running Time | 20.5 hours |

Mast System

| | |
|---------------------|---------------------------|
| Body | Steel Q235 Galvanized |
| Fastener | Stainless steel 304 |
| Wire Rope | Stainless steel 316 8mm |
| Type | Square Telescopic |
| Height | 8.5m |
| Section | 5 |
| Rotation | 360° automatic (optional) |
| Tilt | 90° automatic (optional) |
| Spring Cable | Power Supply |
| Lifting Method | Electric lifting |
| Recommended Loading | 5kg ~ 70kg |
| Windproof | 117kph |

Charger System

| | |
|---------------|------------------------|
| Rated Power | 2.5kW / 2.5kVA |
| Frequency | 50Hz / 60Hz |
| Plug & Socket | 1 x AC 110V/220V Input |

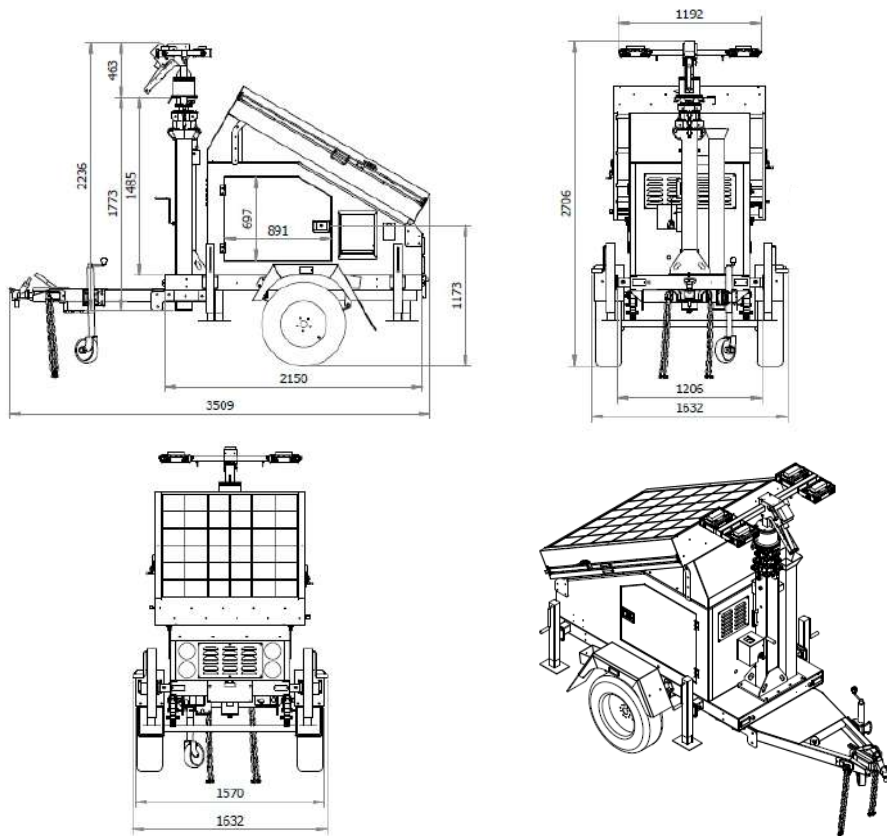

Transport Dimensions

| | | | |
|-----------------|------|-----------------------------------|--------|
| Length (L) (mm) | 2200 | Weight (Kg) | 1300kg |
| Width (W) (mm) | 1600 | Loading capacity in 40 HQ (units) | 07 |
| Height (H) (mm) | 2200 | | |



2400 SQM



0% EMISSIONS



0% NOISE



0% FUEL



**RUN TIME
365 NIGHTS**



07 PER TRUCK

Harvesting Clean Energy / Protecting Our Environment

Battery System

| | |
|---------------------------|---------------|
| Lithium-ion battery (LFP) | 2 x 200Ah BMS |
| Voltage | DC25.6V |
| Power Capacity | 10240Wh |

Control System

| | |
|------------------------|---|
| Solar Controller | Victron MPPT 35A |
| Efficiency | 95%+ |
| Detection & Protection | Short-Circuit, Overload, High Voltage, High Temperature |
| Timer | Manual |
| Whole Machine | Battery Isolator, Light on-off |

Trailer System

| | |
|---------------|------------------------------|
| Standard | US / AU / EU |
| Tow Hitch | 50mm / 2" Ball Type |
| Trailer Light | 7 Pin |
| Jockey Wheel | 200mm / 8" |
| Axle | Single Suspension Bump Brake |
| Tire | 2 x 15 inch |
| Wheel Chock | 2 |
| Forklift Hole | 2 |
| Outrigger | 4 x Manual Galvanized |
| Warranty | 3 years |



Harvesting Clean Energy / Protecting Our Environment

Snarestone Road, Newton Burgoland
Leicestershire, United Kingdom, LE67 2SN

T: +44 300 303 3353 E: sales@dymacuk.com
www.dymacuk.com