

REV	DESCRIPTION	WT	ML	DM
01	ISSUED FOR MANUFACTURING	29.09.2020	29.09.2020	29.09.2020
		PREP. BY	CHG. BY	APPLD. BY

THIS DRAWING AND THE COPYRIGHT THEREIN IS THE PROPERTY OF DYNAMIC GLOBAL. IT MAY NOT BE COPIED WHOLLY OR IN PART AND IT MAY NOT BE LOANED OR DISCLOSED TO OTHERS WITHOUT THE PRIOR WRITTEN CONSENT OF DYNAMIC GLOBAL.

BILL OF MATERIAL FOR FINISHED COMPONENTS			
DyMac GLOBAL		Description	
		FTV-12000L	
		FUEL TAINER VERSATILE 12000L	
Scale	W. O. No.	No. of Units	Drawing No.
NTS	FTV-12000L	ONE	FTV-12000L-GA-01

NOTE: Unless Otherwise Specified: Dimensions are in mm			
TOLERANCES:			
.XX	± 0.1		
.XXX	± 0.005		
ANG.	± 5'		
Drawn	WT	29.09.2020	
Checked	ML	29.09.2020	
Approved	DM	29.09.2020	
Sheets	Rev		
1 OF 5	0		

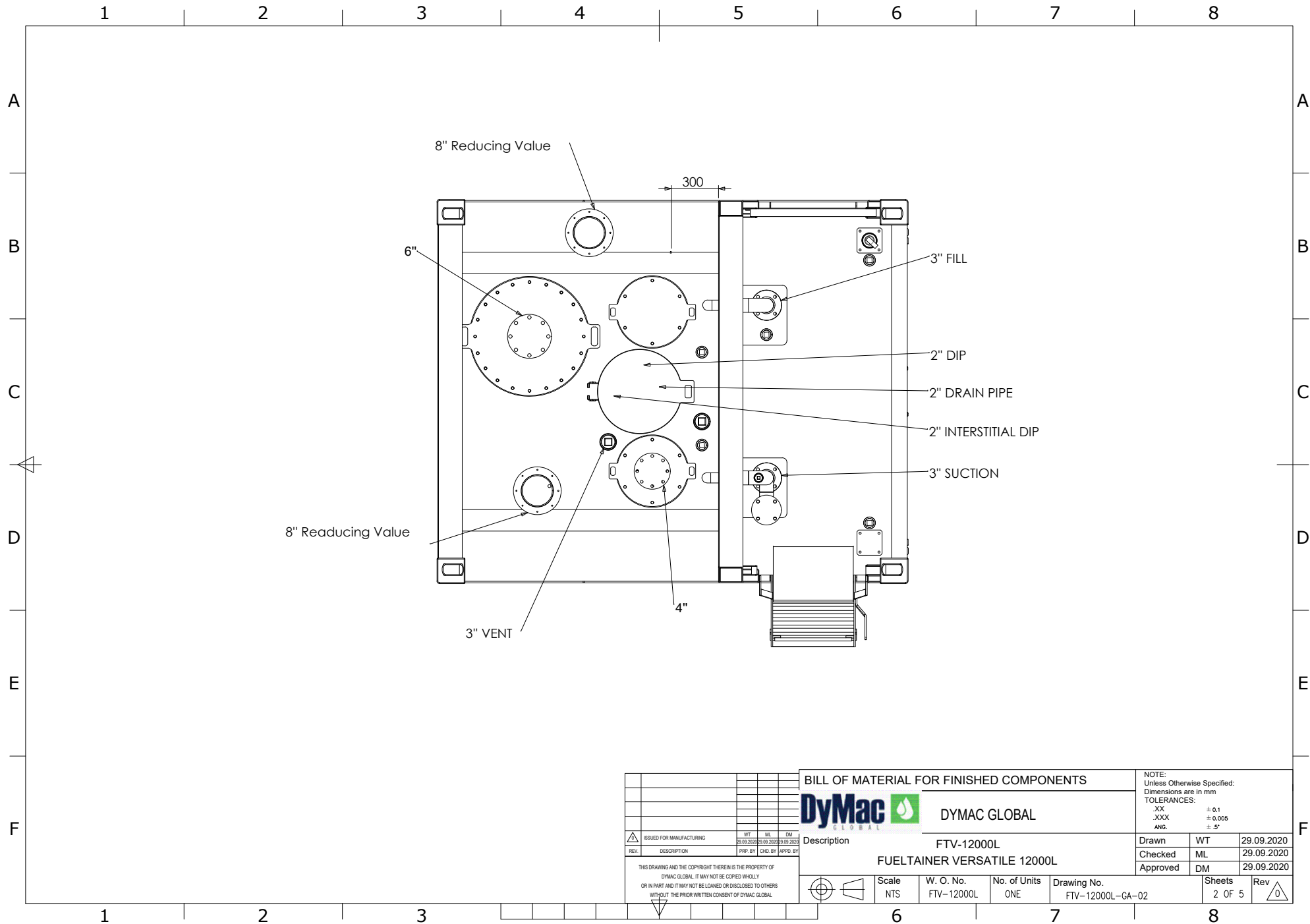

BILL OF MATERIAL FOR FINISHED COMPONENTS				NOTE: Unless Otherwise Specified: Dimensions are in mm		
				TOLERANCES:		
				.XX	± 0.1	
				.XXX	± 0.005	
				ANG.	± .5°	
Description				Drawn	WT	29.09.2020
FTV-12000L				Checked	ML	29.09.2020
FUELTAINER VERSATILE 12000L				Approved	DM	29.09.2020
Scale		W. O. No.	No. of Units	Drawing No.		Sheets
NTS		FTV-12000L	ONE	FTV-12000L-GA-02		2 OF 5
THIS DRAWING AND THE COPYRIGHT THEREIN IS THE PROPERTY OF DYMAC GLOBAL. IT MAY NOT BE COPIED WHOLLY OR IN PART AND IT MAY NOT BE LOANED OR DISCLOSED TO OTHERS WITHOUT THE PRIOR WRITTEN CONSENT OF DYMAC GLOBAL.						Rev
						0

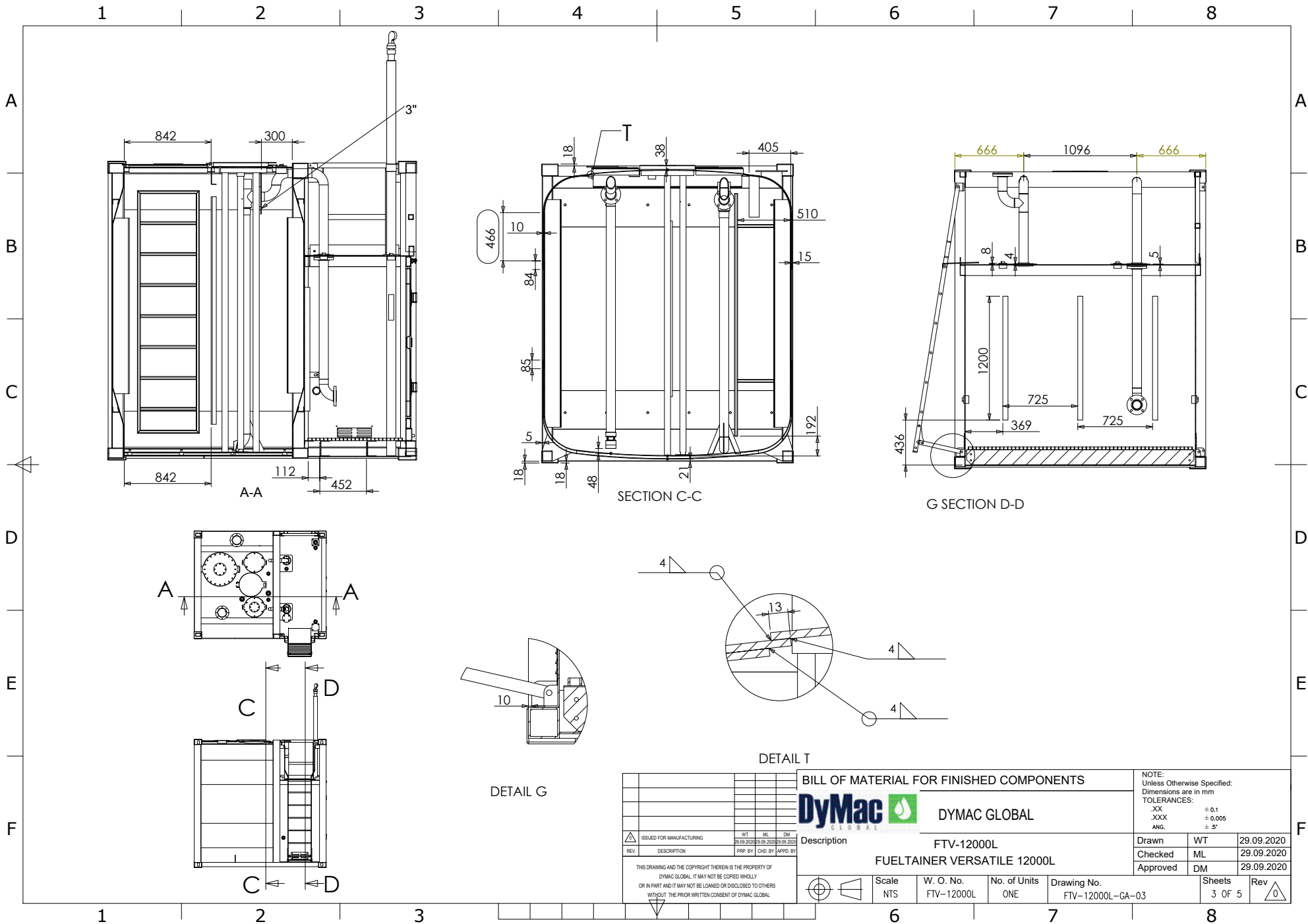

BILL OF MATERIAL FOR FINISHED COMPONENTS				Description		NOTE: Unless Otherwise Specified: Dimensions are in mm TOLERANCES: .XX ± 0.1 .XXX ± 0.005 ANG. ± .5°	
REV	DESCRIPTION	WT	ML	DM	Description		
ISSUED FOR MANUFACTURING					FTV-12000L		
29.09.2020					FUEL TAINER VERSATILE 12000L		
29.09.2020					Scale	W. O. No.	No. of Units
29.09.2020					NTS	FTV-12000L	ONE
						Drawing No.	
						FTV-12000L-GA-03	
					Drawn	WT	29.09.2020
					Checked	ML	29.09.2020
					Approved	DM	29.09.2020
					Sheets	Rev	
					3 OF 5	0	



DYMAC GLOBAL



Scale

NTS

W. O. No.

FTV-12000L

No. of Units

ONE

Drawing No.

FTV-12000L-GA-03

Drawn

WT

29.09.2020

Checked

ML

29.09.2020

Approved

DM

29.09.2020

Sheets

3 OF 5

Rev

0

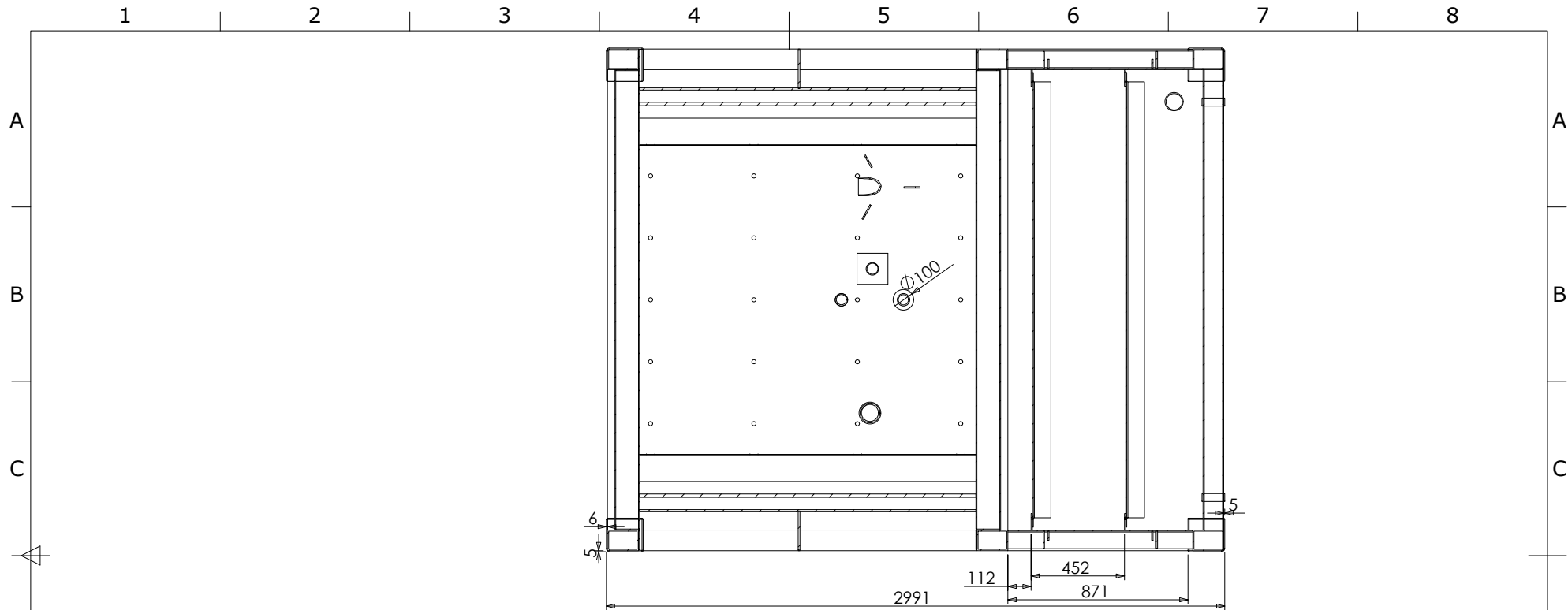

SECTION E-E

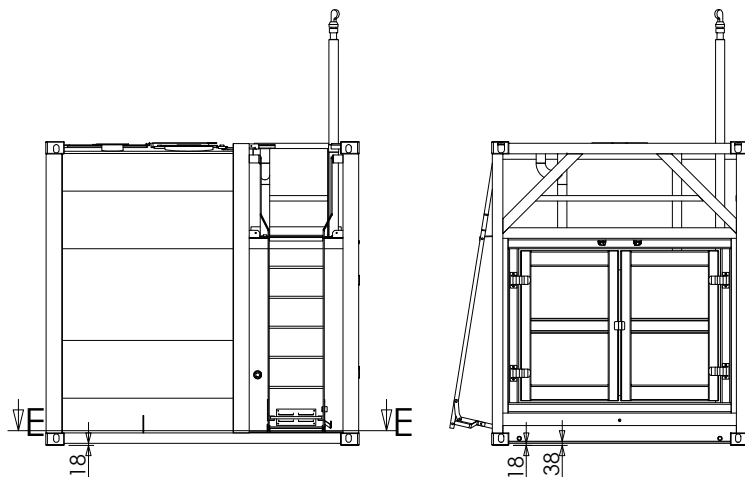

BILL OF MATERIAL FOR FINISHED COMPONENTS				NOTE: Unless Otherwise Specified: Dimensions are in mm		
				TOLERANCES:		
				.XX	± 0.1	
Description				.XXX	± 0.005	
				ANG.	± .5°	
Description				Drawn	WT	29.09.2020
FTV-12000L				Checked	ML	29.09.2020
FUELTAINER VERSATILE 12000L				Approved	DM	29.09.2020
Scale		W. O. No.	No. of Units	Drawing No.		Sheets
NTS		FTV-12000L	ONE	FTV-12000L-CA-04		4 OF 5
THIS DRAWING AND THE COPYRIGHT THEREIN IS THE PROPERTY OF DYMAC GLOBAL. IT MAY NOT BE COPIED WHOLLY OR IN PART AND IT MAY NOT BE LOANED OR DISCLOSED TO OTHERS WITHOUT THE PRIOR WRITTEN CONSENT OF DYMAC GLOBAL.						Rev
						0

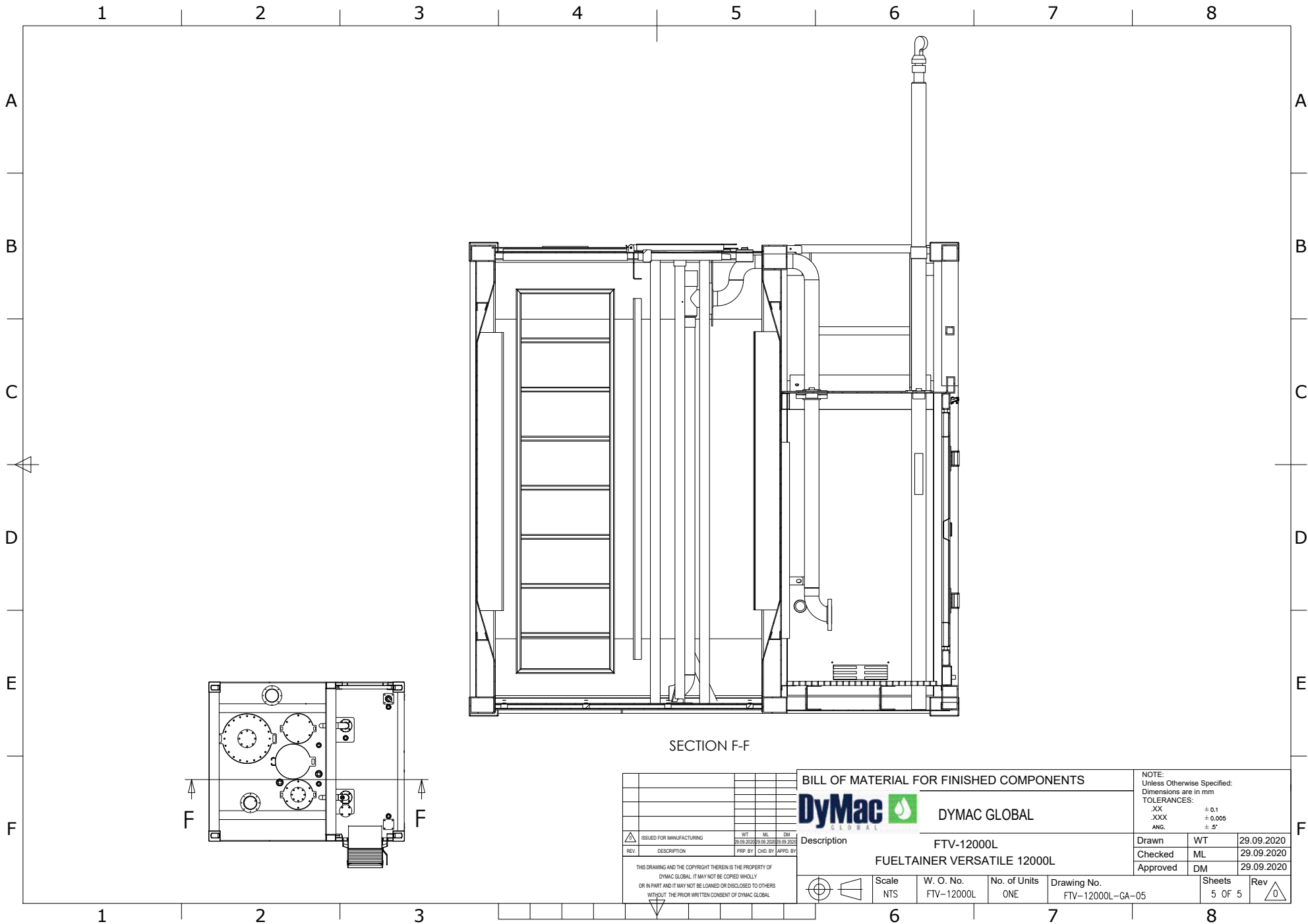

SECTION F-F

BILL OF MATERIAL FOR FINISHED COMPONENTS



DYMAC GLOBAL

NOTE:
Unless Otherwise Specified:
Dimensions are in mm
TOLERANCES:
.XX ± 0.1
.XXX ± 0.005
ANG. ± 5°

REV	DESCRIPTION	WT	ML	DM

ISSUED FOR MANUFACTURING
29.09.2020
PREP. BY: WT ML DM
CHG. BY: WT ML DM
APPD. BY: WT ML DM

THIS DRAWING AND THE COPYRIGHT THEREIN IS THE PROPERTY OF
DYMAC GLOBAL. IT MAY NOT BE COPIED WHOLLY
OR IN PART AND IT MAY NOT BE LOANED OR DISCLOSED TO OTHERS
WITHOUT THE PRIOR WRITTEN CONSENT OF DYMAC GLOBAL

Description	FTV-12000L		
	FUEL TAINER VERSATILE 12000L		
Scale	W. O. No.	No. of Units	Drawing No.
NTS	FTV-12000L	ONE	FTV-12000L-GA-05

Drawn	WT	29.09.2020
Checked	ML	29.09.2020
Approved	DM	29.09.2020
Sheets	Rev	
5 OF 5	0	