



The FuelTainer versatile range come complete with ISO, CSC & UL142 approvals and are a containerised tank design

### Available Sizes

- ✓ FTV-12000L/3128G
- ✓ FTV-17000L/4491G
- ✓ FTV-30900L/8163G
- ✓ FTV-38000L/10039G
- ✓ FTV-68000L/18234G
- ✓ FTV-75000L/19813G



**FUELTAINER**  
versatile

DyMac Global Head Office | Kitsmead Lane | Longcross | Chertsey | Surrey UK | KT16 0EF  
+44 300 303 3353 | sales@dymacglobal.com | www.dymacglobal.com

Company Reg. 10445307



# FUELTAINER

## VERSATILE

### Enhanced Design Features

#### Unique Design Standard

The FuelTainer Versatile Bunded Tank with its rectangle shape is an innovative unique tank design and has become the go-to bulk fuel storage tank solution for industry leaders world wide.

#### Maintenance & Environment

To ensure efficient cleaning and maintenance can take place the tanks have been designed with manway cover lids and an internal integrated ladder system allowing easy access inside the tank to reach the inner tank floors. This innovative design allows flexible inspections top take place and insures a minimal amount of downtime.

#### Dispensing & Accessibility

The FuelTainer versatile Tank comes equipped with a spacious secure equipment compartment area which can house various dispensing pumps and fuel and management systems. It comes with over-head pylons and integrated dispensing hoses & nozzles, allowing the bulk tank to work as a safew and secure independent stand alone fuel station.

#### Transportable & Portable

All FuelTainer versatile tanks have been designed to be easily transported when empty. They come with there own ISO twist locks allowing them to be fixed onto 40ft flat bed trucks and transported over long distances by road.



# Proven Design

## Take a look inside

The Class leading FuelTainer versatile tank range is an ISO,CSC double wall tank design, featuring a fully integrated 6mm inner tank and a 6mm outer protection tank. The range comprises large double cargo doors which open up to a large equipment compartment area allowing the easy up-fitting of various pumps, reels ,flow meters, filters, dispensing equipment and Fuel management systems. Designed as static tanks they are portable when empty and are suited to many fuel and fluid applications world wide.

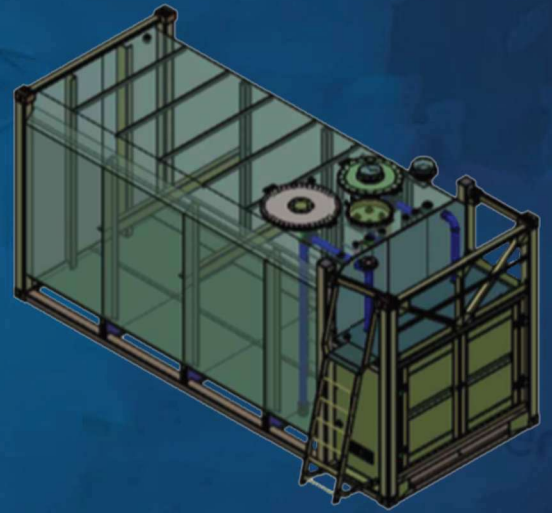

## Superior Features

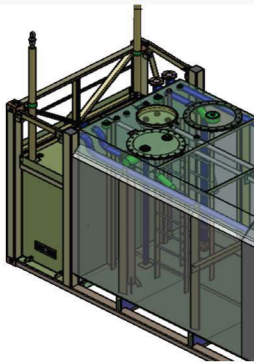

Multiple Ports fittings and Down pipes designed to accommodate various applications

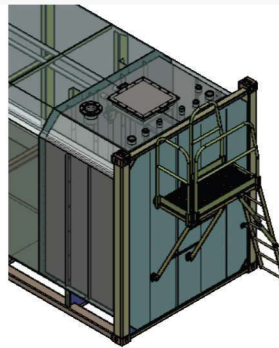

Collapsible ladder and walkway design for ease while in transit.

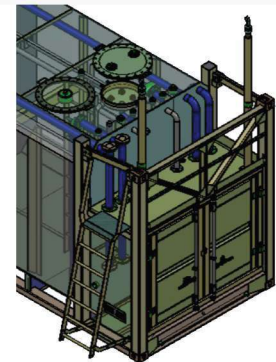

Large double container doors securing an extra large equipment compartment area.

## Optional Accessories



Fuel and Fluid Dispensing Nozzle and Flow Meter Console Options.



Spill Control Floor with Bracket system and retractable hose reel Options.



Filter Options that offer the removal of sediment, scale, rust and water particles from Diesel.

# FUELTAINER

VERSATILE

## Model ( FTV-12000L / 3128G )

The FuelTainer versatile tank is a class leading innovative double wall tank design that provides the safe and secure storage and dispensing of fuels & fluids. The tank can be easily up-fitted with various Pumps, reels, flow meters, filters & dispensing systems.



### Specifications

	Metric	US	Imperial
Capacity	11839 Litres	3128 Gallons	2604 Gallons
Length	2991 mm	117 12/16"	117 12/16"
Width	2438 mm	95 15/16"	95 15/16"
Height	2896 mm	114"	114"
Bund Tank Material	4 mm	2/16"	2/16"
Inner Tank Material	6 mm	3/16"	3/16"
Mass(empty)	4944 kg	10899 lbs, 10oz	10899 lbs, 10oz
Mass(full)	15060 kg	33201 lbs, 10oz	33201 lbs, 10oz
Safe Fill Level	11240 Litres	2969 Gallons	2472 Gallons

### Approvals and Certifications

#### UK & Europe

- ✓ Lifting when Empty
- ✓ UL142
- ✓ ULC S601
- ✓ CSC
- ✓ ISO688
- ✓ AS1940
- ✓ AS1692 CAT. 3

#### Optional

- ✓ BS799

#### USA & Canada

- ✓ Lifting when Empty
- ✓ UL142
- ✓ ULC S601
- ✓ CSC
- ✓ ISO688

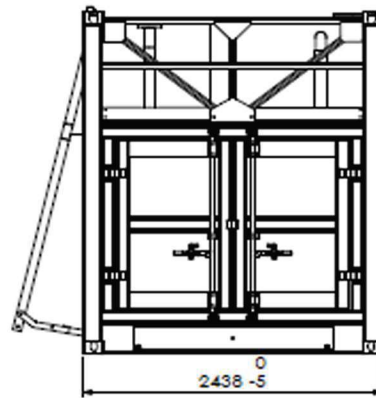
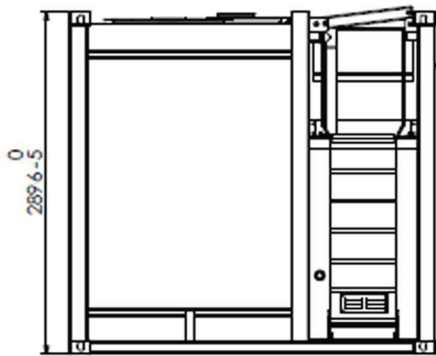
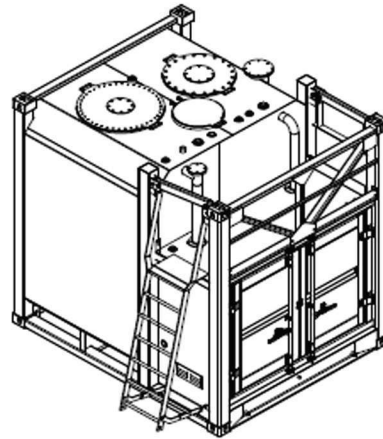
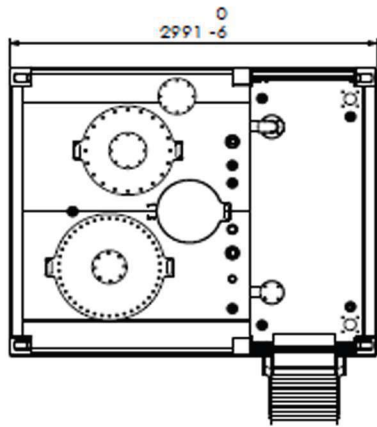

The FuelTainer versatile tank features a large equipment compartment area designed to host various Pumps, Dispensing Stations and STPs brands. Examples shown in the exploded images below.



Fuel Management console Panel



Diesel dispensing station with Dispensing nozzle 80LPM



Red Jacket Submersible Turbine Pump



Blackmer GNX Series pumps provides flow capacities from 7 to 500 gpm (25 to 1,893 L/min)

# FUELTAINER

VERSATILE

## Model ( FTV-17000L / 4491G)

The FuelTainer versatile tank is a class leading innovative double wall tank design that provides the safe and secure storage and dispensing of fuels & fluids. The tank can be easily up-fitted with various Pumps, reels, flow meters, filters & dispensing systems.



### Specifications

	Metric	US	Imperial
Capacity	17000 Litres	4491 Gallons	3739 Gallons
Length	2991 mm	117 12/16"	117 12/16"
Width	2438 mm	95 15/16"	95 15/16"
Height	2896 mm	114"	114"
Bund Tank Material	4 mm	2/16"	2/16"
Inner Tank Material	6 mm	3/16"	3/16"
Mass(empty)	4944 kg	10899 lbs, 10oz	10899 lbs, 10oz
Mass(full)	15060 kg	33201 lbs, 10oz	33201 lbs, 10oz
Safe Fill Level	16150 Litres	4266 Gallons	3552 Gallons

### Approvals and Certifications

#### UK & Europe

- ✓ Lifting when Empty
- ✓ UL142
- ✓ ULC S601
- ✓ CSC
- ✓ ISO688
- ✓ AS1940
- ✓ AS1692 CAT. 3

#### Optional

- ✓ BS799

#### USA & Canada

- ✓ Lifting when Empty
- ✓ UL142
- ✓ ULC S601
- ✓ CSC
- ✓ ISO688

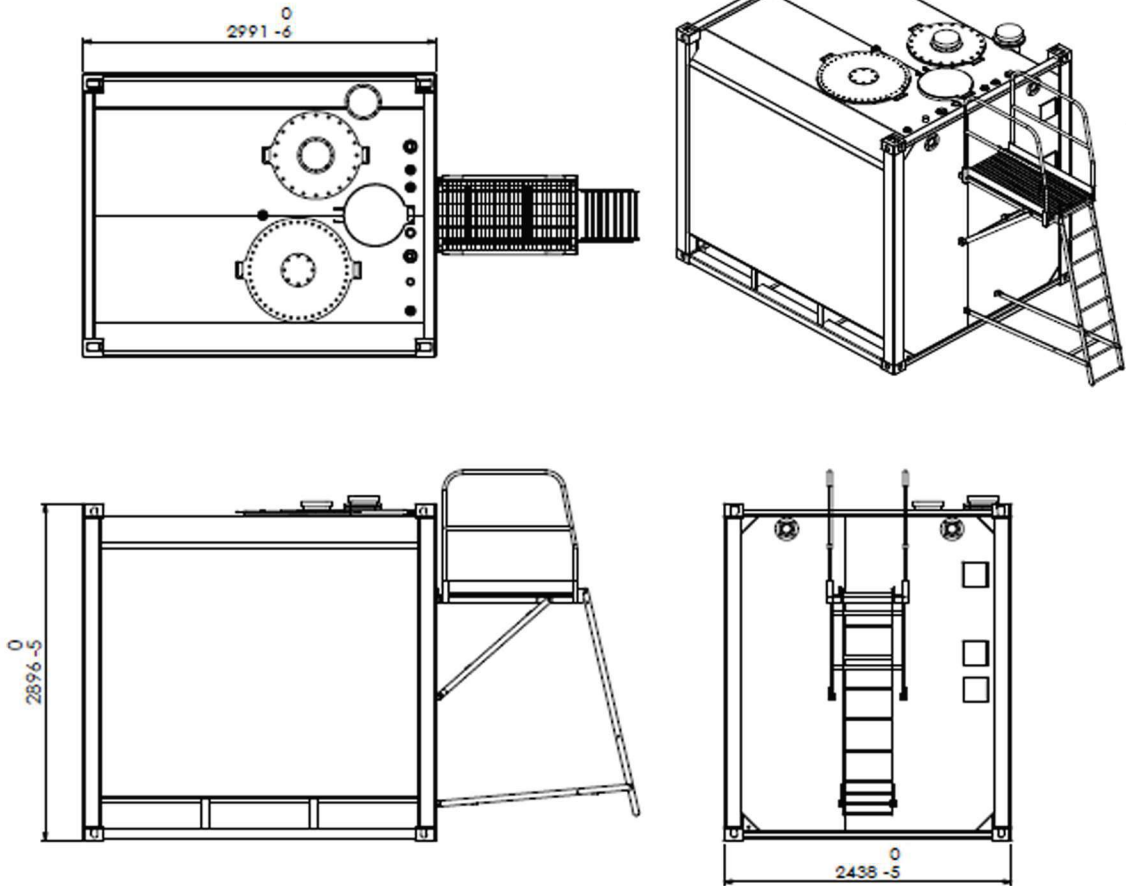

3" Incoming pipe work, male camlock, cap, 80mm fire safe ball valve, wafer check valve, mechanical overfill prevention valve. 3" Discharge pipe work with foot valve.



Male Camlock with cap, 80mm fire safe ball valve.

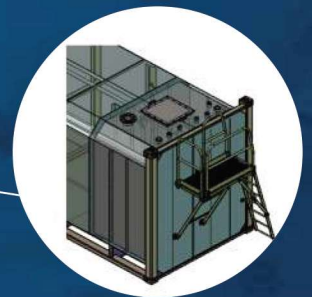

Collapsible ladder and walkway design for ease while in transit.

# FUELTAINER

VERSATILE

## Model ( FTV-30900L / 8163G)

The FuelTainer versatile tank is a class leading innovative double wall tank design that provides the safe and secure storage and dispensing of fuels & fluids. The tank can be easily up-fitted with various Pumps, reels, flow meters, filters & dispensing systems.



### Specifications

	Metric	US	Imperial
Capacity	30901 Litres	8163 Gallons	6797 Gallons
Length	6058 mm	238"	238"
Width	2438 mm	95 15/16"	95 15/16"
Height	2896 mm	114"	114"
Bund Tank Material	4 mm	2/16"	2/16"
Inner Tank Material	6 mm	3/16"	3/16"
Mass(empty)	7837 kg	17277 lbs, 10oz	1727 lbs, 10oz
Mass(full)	34252 kg	75512 lbs, 10oz	75512 lbs, 10oz
Safe Fill Level	29350 Litres	7753 Gallons	6456 Gallons

### Approvals and Certifications

#### UK & Europe

- ✓ Lifting when Empty
- ✓ UL142
- ✓ ULC S601
- ✓ CSC
- ✓ ISO688
- ✓ AS1940
- ✓ AS1692 CAT. 3

#### Optional

- ✓ BS799

#### USA & Canada

- ✓ Lifting when Empty
- ✓ UL142
- ✓ ULC S601
- ✓ CSC
- ✓ ISO688



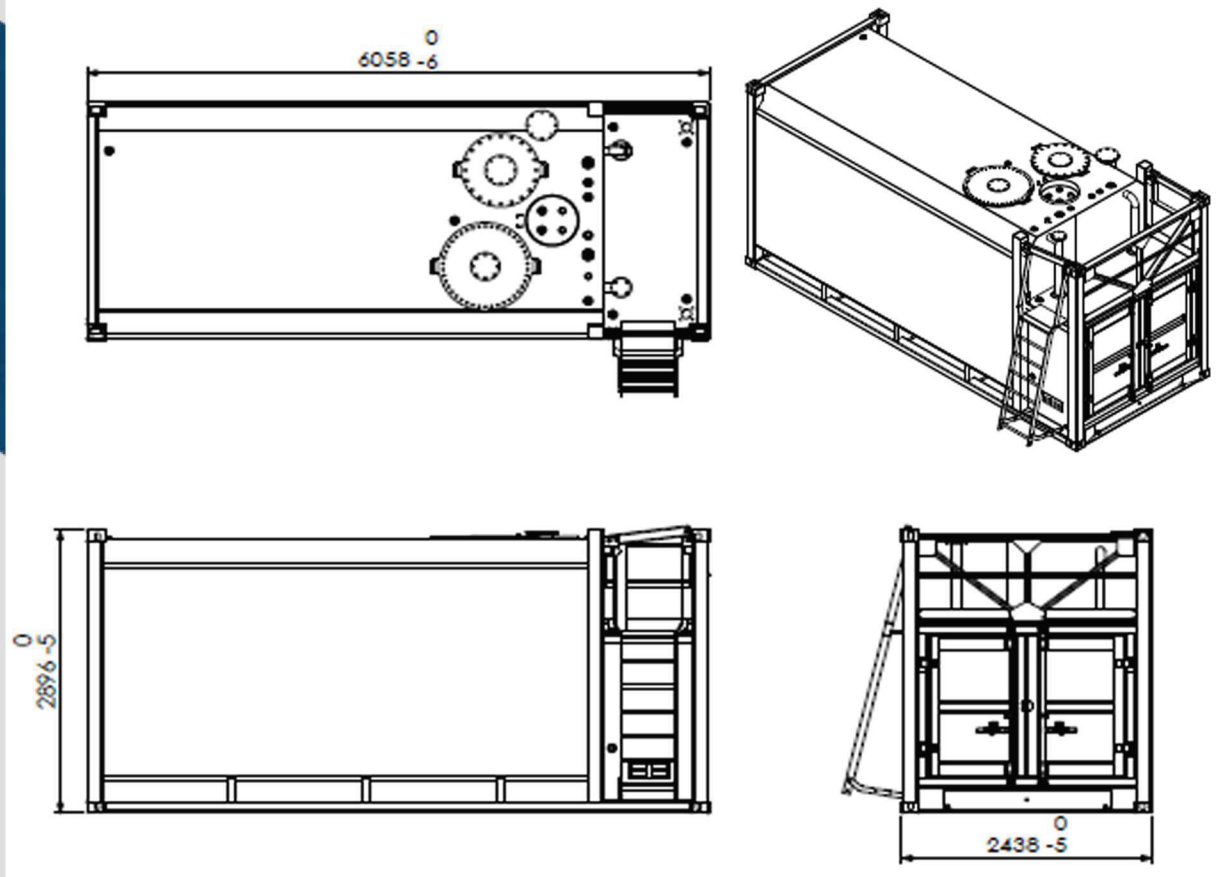

The FuelTainer versatile tank features a large equipment compartment area designed to host various Pumps, Dispensing Stations and STPs brands. Examples shown in the exploded images below.

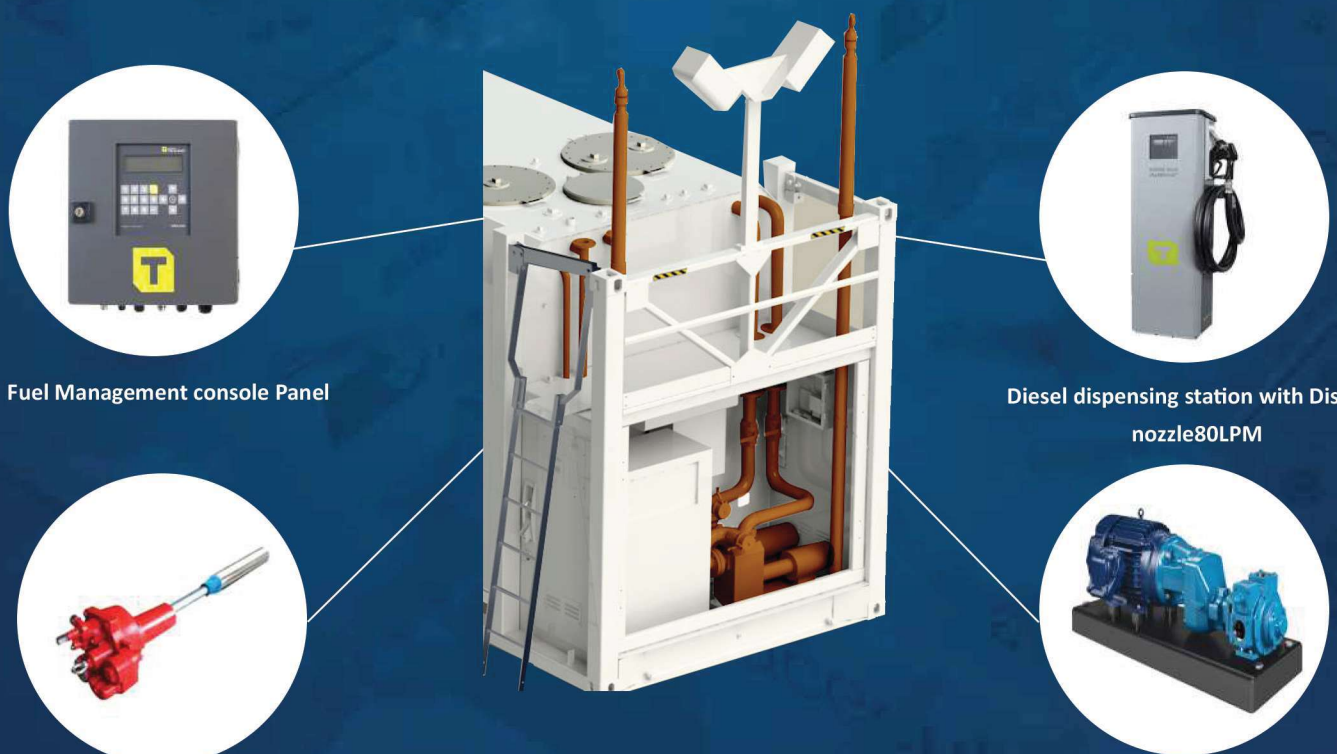

Fuel Management console Panel

Diesel dispensing station with Dispensing nozzle 80LPM

Red Jacket Submersible Turbine Pump

Blackmer GNX Series pumps provides flow capacities from 7 to 500 gpm (25 to 1,893 L/min)

# FUELTAINER

VERSATILE

## Model ( FTV-38000L / 10039G )

The FuelTainer versatile tank is a class leading innovative double wall tank design that provides the safe and secure storage and dispensing of fuels & fluids. The tank can be easily up-fitted with various Pumps, reels, flow meters, filters & dispensing systems.



### Specifications

	Metric	US	Imperial
Capacity	38000 Litres	10039 Gallons	8359 Gallons
Length	6058 mm	238"	238"
Width	2438 mm	95 15/16"	95 15/16"
Height	2896 mm	114"	114"
Bund Tank Material	4 mm	2/16"	2/16"
Inner Tank Material	6 mm	3/16"	3/16"
Mass(empty)	7720 kg	17019 lbs, 11oz	17019 lbs, 11oz
Mass(full)	39568 kg	87232 lbs, 8oz	87232 lbs, 8oz
Safe Fill Level	35380 Litres	9346 Gallons	7783 Gallons

### Approvals and Certifications

#### UK & Europe

- ✓ Lifting when Empty
- ✓ UL142
- ✓ ULC S601
- ✓ CSC
- ✓ ISO688
- ✓ AS1940
- ✓ AS1692 CAT. 3

#### Optional

- ✓ BS799

#### USA & Canada

- ✓ Lifting when Empty
- ✓ UL142
- ✓ ULC S601
- ✓ CSC
- ✓ ISO688

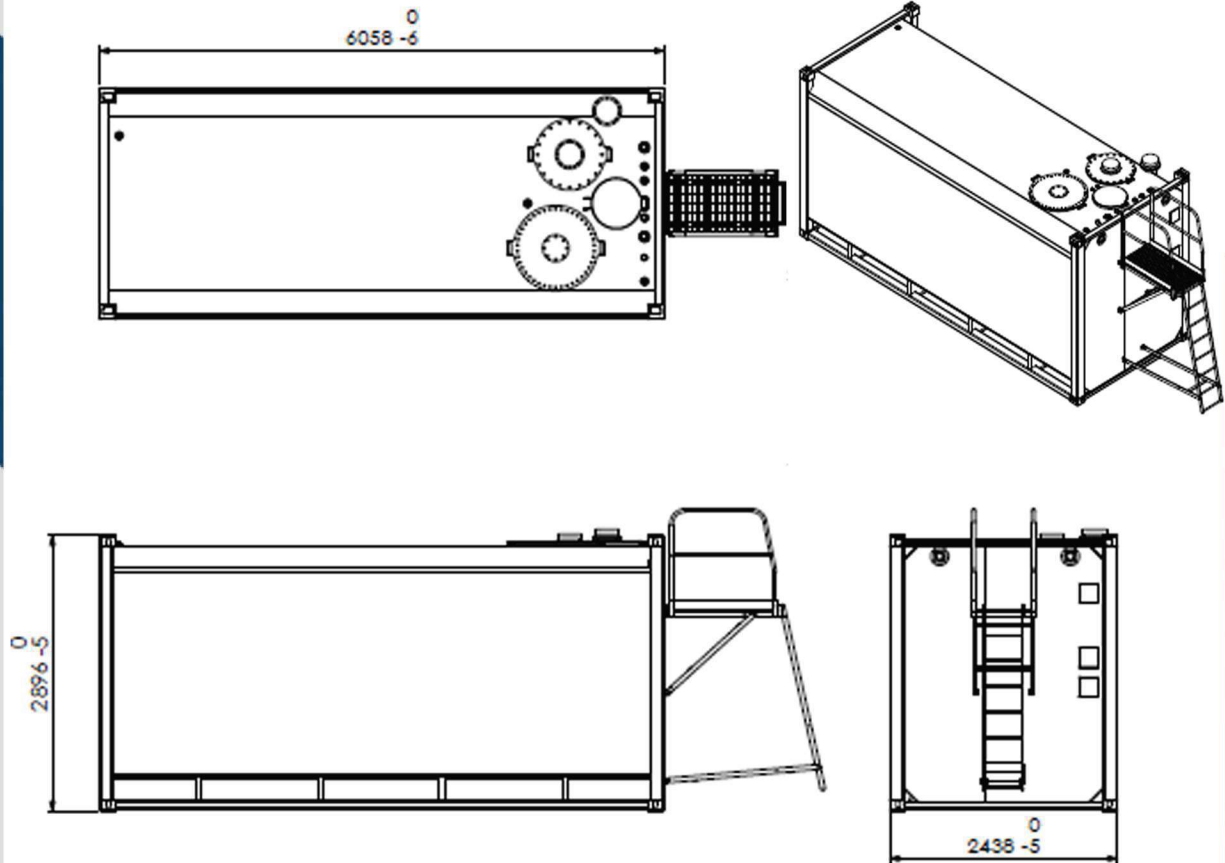

3" Incoming pipe work, male camlock, cap, 80mm fire safe ball valve, wafer check valve, mechanical overfill prevention valve. 3" Discharge pipe work with foot valve.



Male Camlock with cap, 80mm fire safe ball valve.

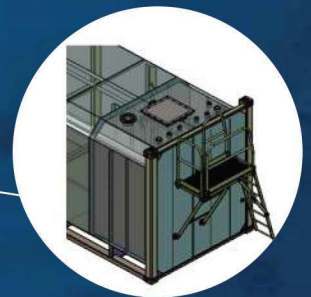

Collapsible ladder and walkway design for ease while in transit.

# FUELTAINER

VERSATILE

## Model ( FTV-68000L / 18234G)

The FuelTainer versatile tank is a class leading innovative double wall tank design that provides the safe and secure storage and dispensing of fuels & fluids. The tank can be easily up-fitted with various Pumps, reels, flow meters, filters & dispensing systems.



### Specifications

	Metric	US	Imperial
Capacity	69023 Litres	18234 Gallons	15183 Gallons
Length	12192 mm	480"	480"
Width	2438 mm	95 15/16"	95 15/16"
Height	2896 mm	114"	114"
Bund Tank Material	4 mm	2/16"	2/16"
Inner Tank Material	6 mm	3/16"	3/16"
Mass(empty)	13459 kg	29672 lbs, 10oz	29672 lbs, 10oz
Mass(full)	72652 kg	160170 lbs, 10oz	160170 lbs, 10oz
Safe Fill Level	65770 Litres	17375 Gallons	14467 Gallons

### Approvals and Certifications

#### UK & Europe

- ✓ Lifting when Empty
- ✓ UL142
- ✓ ULC S601
- ✓ CSC
- ✓ ISO688
- ✓ AS1940
- ✓ AS1692 CAT. 3
- Optional
- ✓ BS799

#### USA & Canada

- ✓ Lifting when Empty
- ✓ UL142
- ✓ ULC S601
- ✓ CSC
- ✓ ISO688

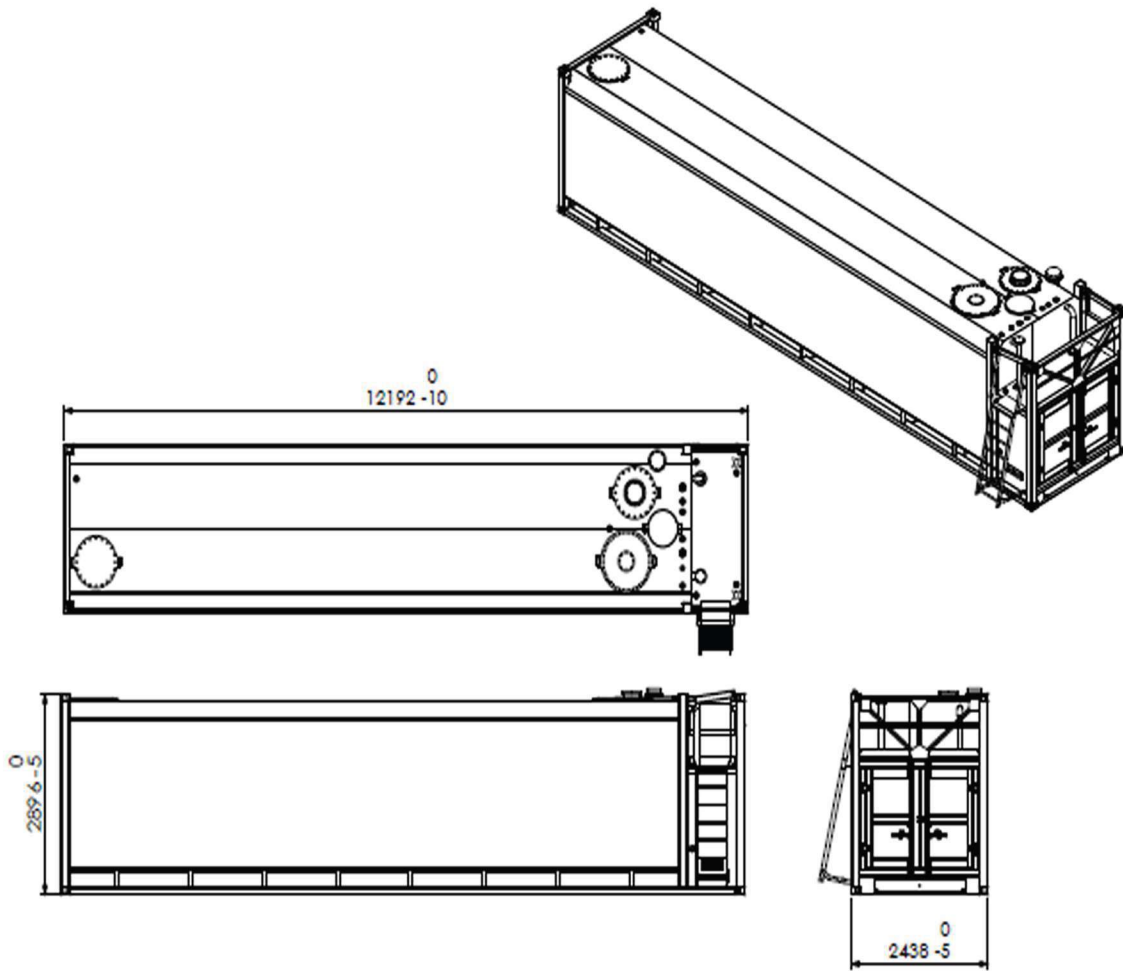

The FuelTainer versatile tank features a large equipment compartment area designed to host various Pumps, Dispensing Stations and STPs brands. Examples shown in the exploded images below.



Fuel Management console Panel



Diesel dispensing station with Dispensing nozzle80LPM



Red Jacket Submersible Turbine Pump



Blackmer GNX Series pumps provides flow capacities from 7 to 500 gpm (25 to 1,893 L/min)

# FUELTAINER

VERSATILE

## Model ( FTV-75000L / 19813G)

The FuelTainer versatile tank is a class leading innovative double wall tank design that provides the safe and secure storage and dispensing of fuels & fluids. The tank can be easily up-fitted with various Pumps, reels, flow meters, filters & dispensing systems.

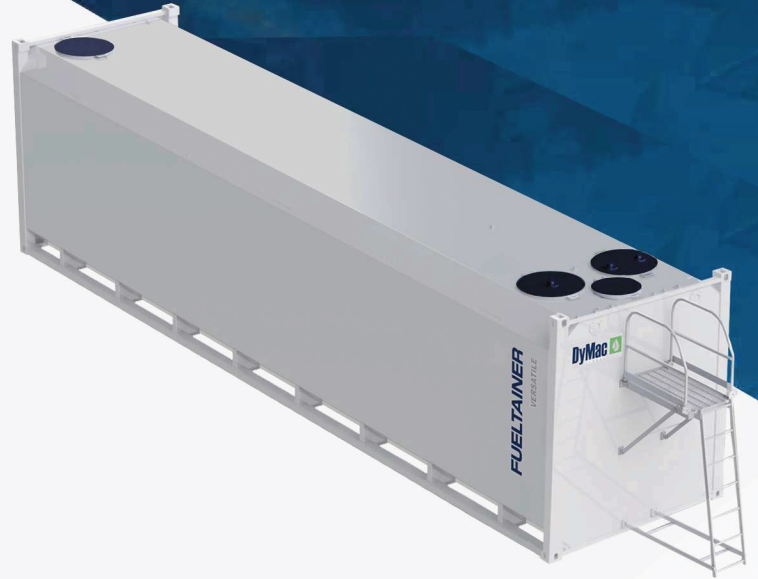

### Specifications

	Metric	US	Imperial
Capacity	75000 Litres	19813 Gallons	16498 Gallons
Length	12192 mm	480"	480"
Width	2438 mm	95 15/16"	95 15/16"
Height	2896 mm	114"	114"
Bund Tank Material	4 mm	2/16"	2/16"
Inner Tank Material	6 mm	3/16"	3/16"
Mass(empty)	13390 kg	29519 lbs, 14oz	29519 lbs, 14oz
Mass(full)	69617 kg	153479 lbs, 3oz	153479 lbs, 3oz
Safe Fill Level	73500 Litres	19417 Gallons	16168 Gallons

### Approvals and Certifications

#### UK & Europe

- ✓ Lifting when Empty
- ✓ UL142
- ✓ ULC S601
- ✓ CSC
- ✓ ISO688
- ✓ AS1940
- ✓ AS1692 CAT. 3

#### Optional

- ✓ BS799

#### USA & Canada

- ✓ Lifting when Empty
- ✓ UL142
- ✓ ULC S601
- ✓ CSC
- ✓ ISO688

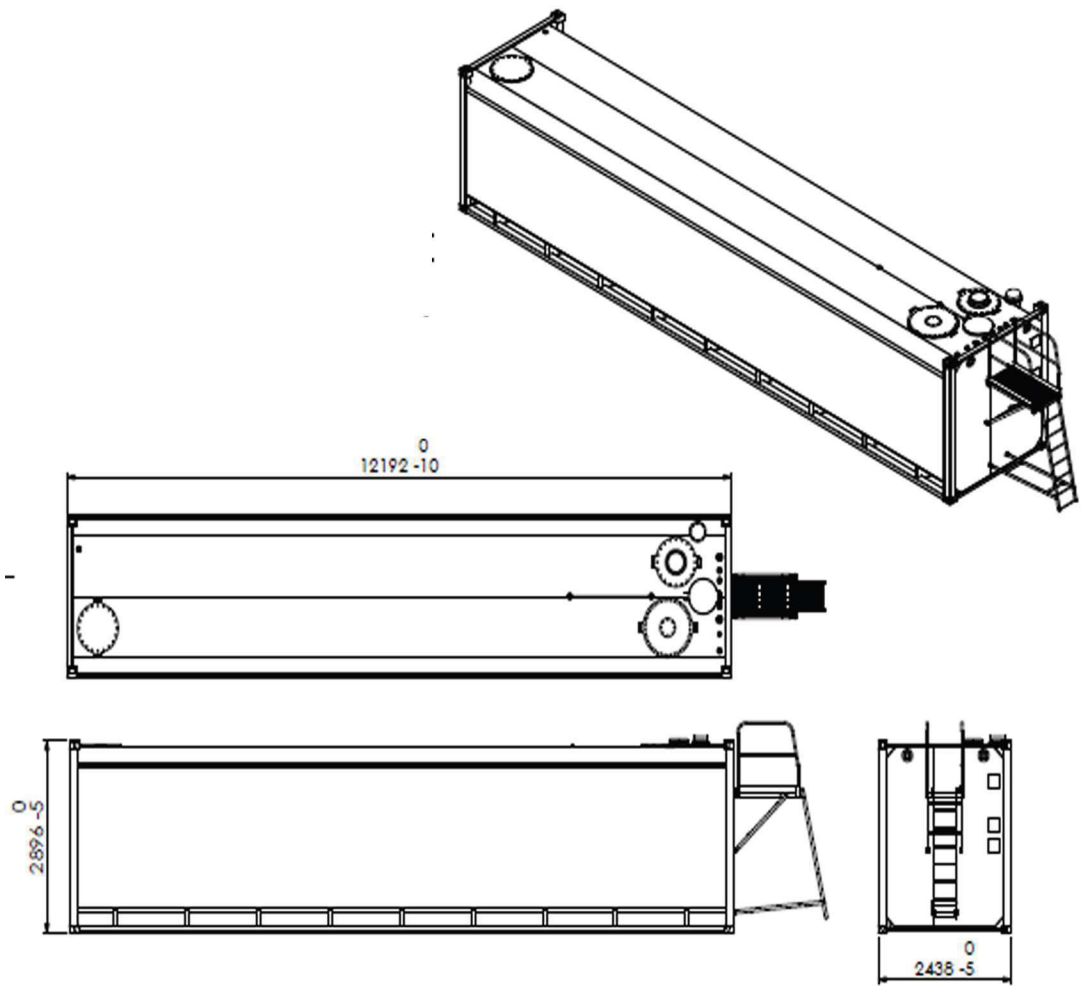

3" Incoming pipe work, male camlock, cap, 80mm fire safe ball valve, wafer check valve, mechanical overfill prevention valve. 3" Discharge pipe work with foot valve.



Male Camlock with cap, 80mm fire safe ball valve.

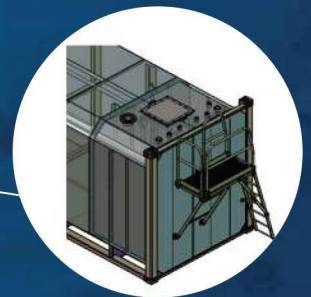

Collapsible ladder and walkway design for ease while in transit.



Fuelling Your Progress

DyMac Global Head Office  
E: [sales@dymacglobal.com](mailto:sales@dymacglobal.com)  
T: +44 300 303 3353  
Kitsmead Lane  
Longcross, Chertsey  
Surrey KT16 0EF  
United Kingdom

DyMac Global India  
E: [india@dymacglobal.com](mailto:india@dymacglobal.com)  
T: +91 8243556957  
Pam Arcade  
3rd floor, Kottara  
Ashok Nagar  
Mangalore - 575006  
India

DyMac Canada  
E: [canada@dymacglobal.com](mailto:canada@dymacglobal.com)  
T: +1 905 564 3654  
Mississauga  
Toronto  
Canada

DyMac Europe / Ireland  
E: [europe@dymacglobal.com](mailto:europe@dymacglobal.com)  
T: +353 1 442 0516  
Unit 3B, Canal Bank  
Hume Avenue  
Park West Ind EST  
Dublin  
Ireland

[www.dymacglobal.com](http://www.dymacglobal.com)