

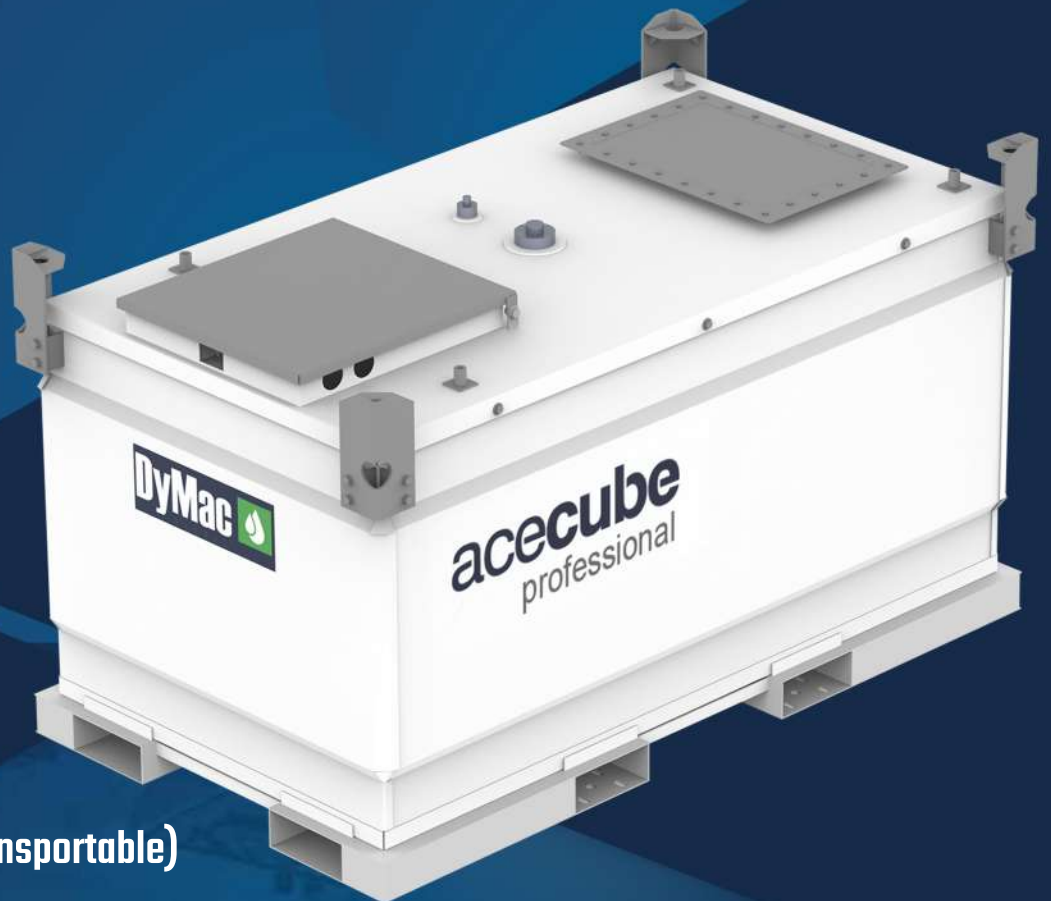

Operations & Warranty Manual



Tank Sizes

- ✓ ACP- 500L/132G (transportable)
- ✓ ACP- 950L/250G (transportable)
- ✓ ACP- 2000L/528G (transportable)
- ✓ ACP- 3000L/792G (transportable)
- ✓ ACP- 4500L/1188G (stationary)
- ✓ ACP- 5300L/1400G (stationary)

acecube
professional

CONTENTS

COVER PAGE	1
CONTENTS	2-3
PRODUCT DETAILS	4
WARRANTY	5-6
Section 1 Introduction	7-8
Section 2 Safety	9
2.1 Warning & Symbols	9
2.2 Safety Symbol Classification	9
2.3 Personal Safety	11
2.4 Work area Safety	12
2.5 Operational Safety	13
Section 3 Components and Functions	14
3.1 Complete AceCube	14
3.2 Hatch Plate Parts & images	15
3.3 Part Descriptions	15

CONTENTS contin.....

Section 4 Operational Procedures	17
4.1 Filling Guidelines	17
Section 5 Maintenance Inspections	18
5.1 Cleaning Instructions	18
5.2 Maintenance Inspection	19
Section 6 Handling & Transportation	20
6.1 Forklift Guidelines	20
6.2 Crane Lifting Guidelines	21
6.3 Removing Inner Tank	22
6.4 Trailer Mounting	23
Section 7 Declaration of Conformity	24

PRODUCT DETAILS

MANUFACTURER	SUPPLIER/DISTRIBUTOR
HEAD OFFICE: DyMac Global Ltd, Long lane farm, Ascot Road ,Holyport , MaidenHead, Berkshire , SL6 3LG , United Kingdom. E:info@dymacglobal.com, T:+44 300 303 3353	
Model No: Purchase Order No:	Purchase Order No:
Serial No:	Job No:
Date of Supply:	Tank Capacity:
Tank Capacity:	Issue Date:
Colour: RAL: Warranty No:	Warranty No:
Notes:	

ALL WARRANTY AGREEMENTS ARE BETWEEN THE CUSTOMER AND THE DYMAC GLOBAL Ltd.

The warranty is subject to the conditions below, your product is supplied with the warranty against material defect in workmanship or materials from the date of supply for the following warranty period. The warranty is based on fair wear & tear basis. Defective parts will be replaced or rectified at the manufacturer's discretion and subject to being returned for full examination at client's cost. For export sales, it is expected that labour would be carried out locally and under the review of DyMac Global. No warranty either explicit or implied is offered for any bought-out items other than those offered by the manufacturer.

ACECUBE – PROFESSIONAL BUNDED STEEL TRANSPORTABLE TANKS: 3 YEARS

PAINT WORK: 1 YEAR

ACCESSORIES:

DESPENSING PUMPS, DELIVERY NOZZLES, SUCTION/DELIVERY HOSES: 90 DAYS

ALL OTHER ACCESSORIES: 1 YEAR

The warranty is subject to following conditions:

To qualify for the guarantee this product must be installed by a registered competent person in accordance with prevailing statutory requirements. The period of the warranty will commence from the date of invoice. The warranty is provided to the original purchaser, only proof of the purchase and evidence of annual inspection by a registered competent person will be required in the event of a claim.

**HEAD OFFICE: DyMac Global Limited, Long lane farm, Ascot Road, Holyport
MaidenHead, Berkshire, SL6 3LG, United Kingdom.
E: info@dymacglobal.com, T: +44 300 303 3353.**

WARRANTY

During the warranty period, any component of your product which is proved to contain any material defect in workmanship or materials will be exchanged or repaired, at our sole discretion by us free of charge for material or labour.

In respect of your product, the warranty does not cover (and we will not accept responsibility for) any consumable items, any component which has not been manufactured by us (please refer to the manufacturer's warranty supplied with the relevant component), fair wear and tear, or any fault;

- In respect of any component not forming part of your product; or
- Arising from any cost other than defect in original workmanship or materials; or
- Caused improper installation, maintenance, neglect, misuse or willful or accidental damage; or
- Caused by alteration or repair by you or by a third party who is not one of our authorized repairers; or
- Caused by non-observance of either any applicable statutory requirement or any of the instructions contained in the installations and operating instructions appropriate to your product and in this respect.

Your product has been used only for the purpose for which it is designed, and that any terms and conditions held with your installer have also been adhered to.

To the maximum extent permitted by UK law:

- The warranty is given in lieu of all other warranties, expressed or implied by statute or common law, including implied warranties or conditions of satisfactory quality and fitness for a particular purpose, provided that this warranty is in addition to your legal rights in relation to goods that are faulty or not as described; and
- We shall not in any circumstances be liable to you or any other party, whether in contract or (including for negligence and breach or statutory duty howsoever arising), misrepresentation (whether innocent or negligent), restitution or otherwise, for any special, indirect or consequential loss or damage.

1. INTRODUCTION

Thank you for the purchase of AceCube. This accompanying manual will help you safely operate and maintain your new tank. The following information in this manual will ensure years of safe, reliable service and production. Please ensure that all owners, operators or any other persons working near or on the AceCube read and understand this manual. Following the procedures and maintenance schedules as outlined in this manual will help to:

Avoid dangers / Reduce costly repairs, Clean-ups, and Downtime / Increase the reliability of the AceCube.

The AceCube is designed and built to the highest standards using quality materials and components. DyMac Global has taken the greatest care to insure that you have received a safe and reliable product that will provide you with years of service. The AceCube is designed with the highest regard of safety. Nonetheless misuse of this product may result in serious injury, death, damage to the tank as well as void the manufacturer's warranty.

Products Designated Use

The AceCube Professional ACP-500L/132G, ACP-950L/250G, ACP-2000L/528G, ACP-3000L/792G, is a transportable fuel tank designed to be moved when full via its built in forklift pockets or lifting eyes. It is stackable both in shipping containers and on the truck beds, 2 high when full 3 high when empty. ACP-4500L/1188G, ACP-5300L/1400G are stationary tanks. Its outer bund tank is 110% the capacity of the inner tank, ensuring the outmost level of security and environmental protection in the event of a leak DyMac Global cannot be liable for any damages resulting from misuse.

Contacting DyMac Global: if you have any questions regarding your product, please contact us at on the following numbers:

United Kingdom office: +44300 303 3353,

By calling these numbers you can reach anyone of the following departments; service, sales, production, accounting and engineering.

HEAD OFFICE: DyMac Global Limited, Long lane farm, Ascot Road, Holyport

MaidenHead, Berkshire, SL6 3LG, United Kingdom.

E: info@dymacglobal.com, T: +44 300 303 3353.

1. INTRODUCTION

OVERVIEW OF SECTIONS

The following briefly outlines each section and its contents.

Safety

Safety information related to all aspects of tank including safety warnings, proper filling, transportation and storage.

Components and Functions

Includes information on the functions of various components of the product, and their proper usage.

Operation Procedures

Includes information on how to properly and safely make use of the AceCube.

Maintenance

Provides instructions on proper cleaning as well as Maintenance Schedules.

Handling and Transportation

Provides guidelines for safely transporting, handling, and storing the product.

Problems Errors and Omissions

We believe this manual will provide you with the necessary information to successfully operate and maintain your product. If you believe that this manual contains an error, or you encounter a problem while following the guidelines in this manual, or if you believe this manual may be missing information, please contact us so we may rectify any problems.

Copy Right

This document is copyrighted to DyMac Global. Any information, text, drawings or technical data contained in this document cannot be copied, disturbed, altered, and stored on electric media, revealed to others or used for the purpose of competition.

2. SAFETY

2.1 WARNINGS AND SYMBOLS

Most operations involving product operation, service and transportation are caused by failure to observe basic safety rules and precautions. Recognizing all possible safety hazards before acting can often prevent accidents. Any person(s) involved in the operation, maintenance or transportation of this tank must observe each situation for potential hazards. The persons(s) must also possess the required knowledge, skill and equipment required to perform these tasks appropriately. The warnings located on the tank and those in this publication are NOT inclusive. DyMac Global strives to foresee all potential hazardous situations but cannot anticipate every possible situation that can prove potentially hazardous. For any function performed not recommended by DyMac Global, you must satisfy yourself that it is safe for you and for others and the action must not compromise the safety or function of the product.

2.2 SAFETY SYMBOL CLASSIFICATIONS



(1) Safety Warning Symbol

The safety warning symbol indicates a risk of personnel injury. Follow all instructions which appear after this safety warning symbol in order to avoid injury or fatal accidents.

2. SAFETY

(2) ANSI Hazard Classification systems



This indicates a hazardous situation, which if not avoided will result in death or serious injury. The safety alert symbol is shown with this danger classification.



This indicates a hazardous situation, which if not avoided will result in death or serious injury. The safety alert symbol is shown with this danger classification.



This indicates a hazardous situation, which if not avoided will result in death or serious injury. The safety alert symbol is shown with this danger classification.



This indicates a message related to property damage. The safety alert symbol is not shown with this danger classification.

(3) Description of safety symbols

This tank is fitted with a number of safety warning decals to highlight potential risks. These warnings must be obeyed at all times. If one of the decals become detached or damaged it must be replaced. The safety decals use pictogram to indicate the relevant risk in line with ISO requirement's and pictograms with text in line with ANSI requirement's and will be equipped with same dependent on your region.

As determined by TDG it is imperative that you check the local requirement's for labeling before loading the tank with dangerous goods. The appropriate decals should be applied to the tank in the line with local authority requirements.

2. SAFETY

2.3 PERSONAL SAFETY

Ascertain from the appropriate authority and observe all statutory and any other regulations that may apply to the planned location before operating the product. Operators must be trained in the correct and safe use of all equipment.

Before operation the operator(s) must:

- Have received specific and adequate training in the task to be carried out.
- Have read and understood the operations manual and the safety signs in this manual and around the product(s).
- Knows the location and function of controls and safety features.
- Be aware of all moving parts of the equipment.

Any work on and/or with the product must be executed by trained, reliable and authorized personnel only.

Statutory minimum age limit must be observed.

Work on the hydraulic system must be carried out only by personnel with special knowledge and experience of hydraulic equipment.

It is the responsibility of the persons using this tank to ensure that the correct placards are fitted before transporting the tank. Please refer to the appropriate legislation in your region.

WARNING

- Warning - Fill through the 2" fill cap only.
- When filling through the 2" fill cap with non-return valve please open the 3" fusible fill cap for venting purposes, close the 2" fill cap and 3" fusible fill cap when tank has been filled.

2. SAFETY

2.4 WORK AREA SAFETY

Operators must have received specific training in all operating and service tasks as required for the safe operation and service of the tank. Operators must know the location and correct operation of all controls and safety features.

Only authorized and trained personnel involved in tanks operation or maintenance should be in the vicinity of tank while it is being used or serviced. All other personnel should be kept at a safe distance.

Keep the work area as neat and as clean as practical. Keep your equipment clean and free of dirt and grease so it can be checked for loose, cracked or broken parts. Replace defective parts as soon as they are discovered.

Do not smoke or allow smoking near flammable fuels or solvents. Use non-flammable solvents for cleaning parts and equipment. Know where fire extinguishers and other fire suppression equipment are located and learn how to use them.

Always use proper hoisting equipment for heavy loads. Regularly check hooks, cables, shackles and chains for stretch and wear. Never overload hoists, cranes or other lifting devices.

Avoid electrical and static sparks and any open flame while handling, storing, moving or pouring fuels, electrolytes for batteries, hydraulic fluids or coolants.

2.5 OPERATIONAL SAFETY

Safety warnings are required to be displayed in the area of the fuel dispensing equipment which must include the slogan “DANGER – NO SMOKING, NO NAKED FLAMES”

- All personnel involved in the handling and storage of the fuels must have, or be supervised by those who have, adequate knowledge, experience, and training in the handling of fuels and in accident prevention and response.
- NEVER store fuel tanks within:
 - 8 meters of any ignition source.
 - 5 meters from overhead wires.
 - 3 meters of combustible vegetation.
 - 15 meters from property boundaries.
 - 15 meters from any dwelling, workshop, or stockpile of combustible materials.
- Ensure fuel tanks are stored clear from areas with heavy vehicle traffic.
- When storing multiple fuel tanks, ensure that adjacent tanks remain more than 600mm apart.
- Never store fuel in outer bund reservoir.
- Read and keep the maintenance instruction supplied with all the equipment you will be using with tank.
- Dispenser hoses must be approved anti-static hoses in good condition.
- All fittings, pumps, valves and hoses must be monitored for leaks regularly.
- Ensure that safety instructions and warnings attached to the equipment are always complete and perfectly legible.
- Keep warnings and instruction labels clean and up to date.
- Only use approved fuel pumps with the tank, and ensures that the pumps are installed near the supply tank.
- Ensure a cleared working space is allowed around the fuel pumps.

3. COMPONENTS & FUNCTIONS

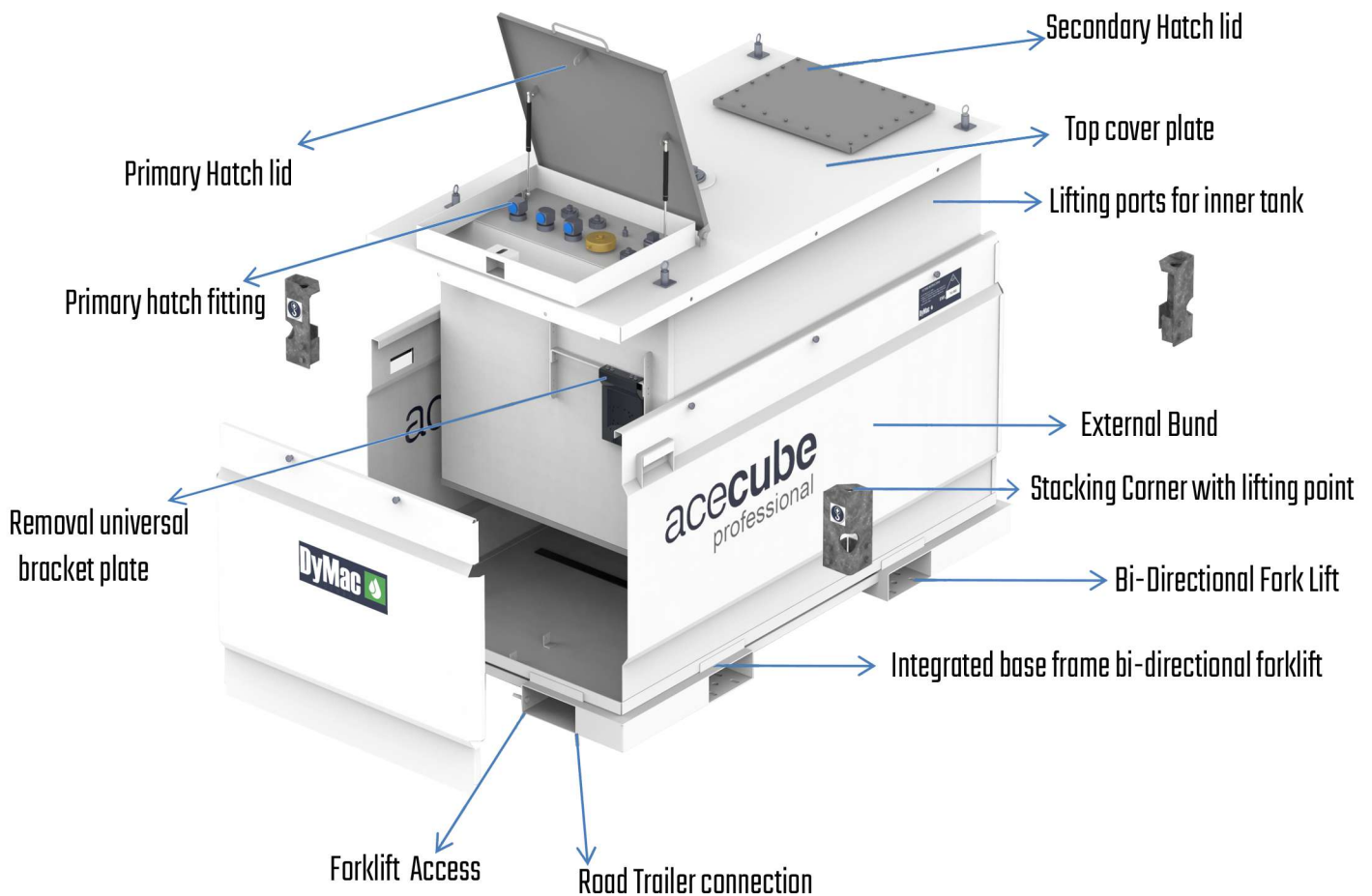

3.1 COMPLETE ACECUBE



DIMENSIONS												
	ACP-500L/132G		ACP-950L/250G		ACP-2000L/528G		ACP-3000L/792G		ACP-4500L/1188G		ACP-5300L/1400G	
	METRIC	INCHES	METRIC	INCHES	METRIC	INCHES	METRIC	INCHES	METRIC	INCHES	METRIC	INCHES
HEIGHT	807	2'7"	1295	4'3"	1295	4'3"	1295	4'3"	1295	4'3"	1295	4'3"
WIDTH	1150	3'9"	1150	3'9"	1325	4'4"	1885	6'2"	2299	7'6"	2299	7'6"
LENGTH	1485	4'10"	1485	4'10"	2300	7'6"	2300	7'6"	2650	8'8"	2995	9'10"

3. COMPONENTS & FUNCTIONS

3.2 HATCH PLATES PARTS & IMAGES

PRIMARY FITTING PLATE			LEVEL GAUGE OPTIONS		
			 <p>Alternative type eg Rochester</p>		 <p>Standard Float Type Dial Gauge</p>
 <p>Fuel Return</p>	 <p>Pressure Vent</p>	 <p>3" Fill/Fusible Cap</p>	 <p>2" Fill Cap</p>	 <p>Fuel Feed/Suction</p>	 <p>Emergency Vent</p>

3.3 PARTS DESCRIPTION

Inner Tank: The inner tank is a primary storage tank having all fuel transfer accessories and eternally encased within an outer bund tank.

Outer Tank: Outer bund designed to contain 110% of the inner tank volume it surrounds & wraps the main inner tank unit, has the interstitial space between inner and outer tanks. Therefore any potential leak that may occur will be captured in this sealed space, preventing the release to the environment.

Top Lid: The top plate used to cover the inner tank.

3. COMPONENTS & FUNCTIONS

Fuel Fill: Fuel fill inlet used to fill the inner fuel tank in a secure way, without sparks and spillages. Automatic or manual nozzles can be used for filling.

Fuel Suction: Tank access point for removal of fuel from the inner tank to either a transfer pump for manual dispensing or feed to a genset or other engine driven unit.

Fuel Return: Used as a return inlet for the excess fuel withdrawn from the tank.

Normal Vent: Used to relieve vacuum and pressure of fuel as it expands and contracts.

Emergency Vent: Emergency vents are installed on above ground storage tanks as a code requirement. Emergency vents provide high capacity pressure relief if the tank is exposed to fire. When the internal tank pressure reaches the opening pressure of the emergency vent, the weighted cover moves upon the center pin allowing air to escape. When the internal tank pressure falls, the cover automatically lowers back.

Fuel Level Gauge: A fuel gauge is used to indicate the level of fuel contained in the tank. To measure or evaluate the remaining quantity of the fuel in the tank.

Dispensing Pump: The Dispensing pump takes the fuel from the Inner tank through the pump suction port to a dispensing hose and nozzle with automatic shutoff.

Note: Over-fill provision can be provided as per client request.

4. OPERATIONAL PROCEDURES

4.1 FILLING GUIDELINES

This tank is designed for the storage of diesel fuel, petrol, kerosene, oils, water and certain bio fuels.

- Ensure tank is on level ground before filling.
- Fill only with trigger nozzle.
- Do not smoke when re-fuelling: keep sparks, flame, and hot material away from the tank.
- Do not over- fill, 95% capacity is the maximum fill limit.
- Replace filler cap and store all hoses and nozzles inside the cabinet.
- Check bund area and empty regularly, refer to maintenance refer to maintenance schedule for full maintenance procedures.
- Follow the regulations for transport of all dangerous goods.
- Thread type BSP except for tanks built for US/Canada NPT.
- All ports need to be closed during transportation to avoid spilling of fuel out from tanks.
- When hoses are connected to feed and return ports should have quick releasing coupling on each hoses to prevent fuel coming out from tank during transportation.



5. MAINTENANCE

5.1 CLEANING INSTRUCTIONS

1. Remove lid inner tank.
2. Empty fuel from inner tank into an approved receptacle
3. Clean the inside of the outer tank (bund tank). Remove all debris and liquids.
4. Remove fittings/access plate from the inner tank.
5. Clean out any residue from inside the inner tank.
6. Pressure wash both inner and outer tanks, drain and dry.
7. If it is necessary to enter the tank, for maintenance or inspection, a safe working procedure should be approved and work carried out by a qualified engineer.
8. It is recommended that after the tank has been cleaned a leak inspection is carried out, to do this:
 - Replace pressure/vacuum relief valve with a plug.
 - Reassemble the tank and install a new gasket around the access cover.
 - Secure all bolts to ensure that there is no leakage.
 - Carry out a leak test.
 - Reinstall the pressure/vacuum relief valve after the leak test.
 - Keep all records for testing with the unit at all times.

5. MAINTENANCE

5.2 MAINTENANCE INSPECTIONS

Ensure that any repairs are made using only genuine replacement parts from DyMac Global.

1. Daily Inspection:

- Check fuel level.
- Look for any major leakages.
- Inspect hoses, valves, and couplings for damage/leaks.
- Inspect electrical wires, terminal and connections for damage and disconnections.

2. Weekly Inspection:

- Visually check the bund tank to see that there have been no leaks from the primary tank or spills during fuel transfers. If any liquid is found in the bund pump it into an approved container, seal and dispose of it in accordance with local regulations.
- If the bund is found to contain material unable to be pumped out, it is recommended to remove the inner tank and wash out the outer tank in a secure bunded area without runoffs.

3. Monthly Inspection:

- Lubricate spring bolts, hinges, and locks.
- Clean out pump and line filters and strainers.
- Visually inspect tank, hoses, valve, pump and other components for cracks, corrosion and leaks.
- Empty and clean tank (5.1).

6. TRANSPORTATION & HANDLING

6.1 FORKLIFT GUIDELINES

The ACP-500L/132G to ACP-3000L/792G may be transported empty using a forklift of 3 Ton capacity or higher. Using forklift 3 & 4, the tank may be transported both full and empty. The tank may be transported empty only using forklift pockets 1 & 2. The tank may be transported full on the highway. When tanks are in use, all ports and valves installed on each feed/return lines will be closed during transport. Forklift should be sized to match the total load of the tank and its contents.

The ACP-4500L/1188G to ACP-5300L/1400G may be stacked 2 units high with both units being full, and 3 units high with the bottom unit being full and the top 2 being empty.

Lifting/Stacking
Brackets

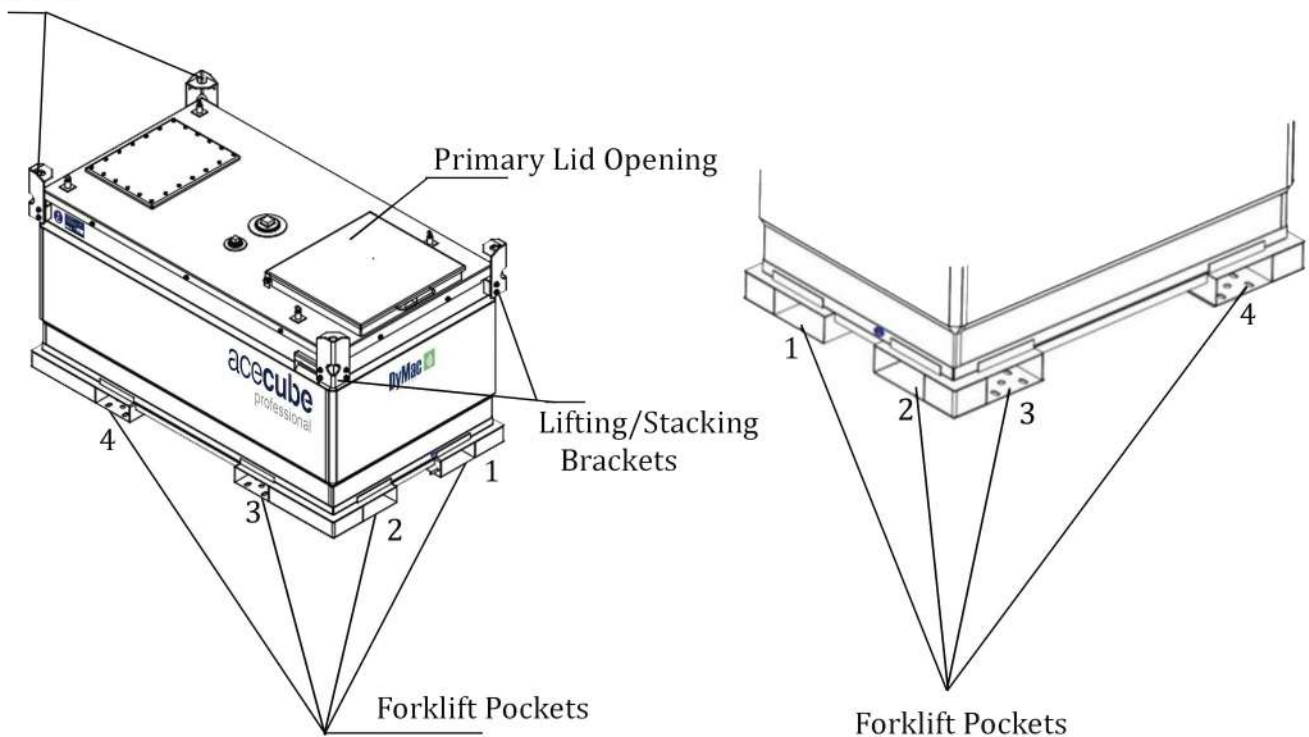

*Image may not represent your exact tank model

WARNING

Only properly trained and licensed forklift operators who have knowledge of hazardous material handling should transport AceCube. Failure to adhere to this could result in serious injury or death.

6. TRANSPORTATION & HANDLING

6.2 TOP lift by crane

This tank has been tested in accordance with the testing criteria of UN31A/Y for safe lifting by crane from its top lifting points when the tank is full of liquid. Please check the MPMG stated on the tanks data plate to ensure the correct lifting slings/chains and crane is used for this top lift process. Ensure that the tank is free from any obstructions and follow local safe lift precautions.

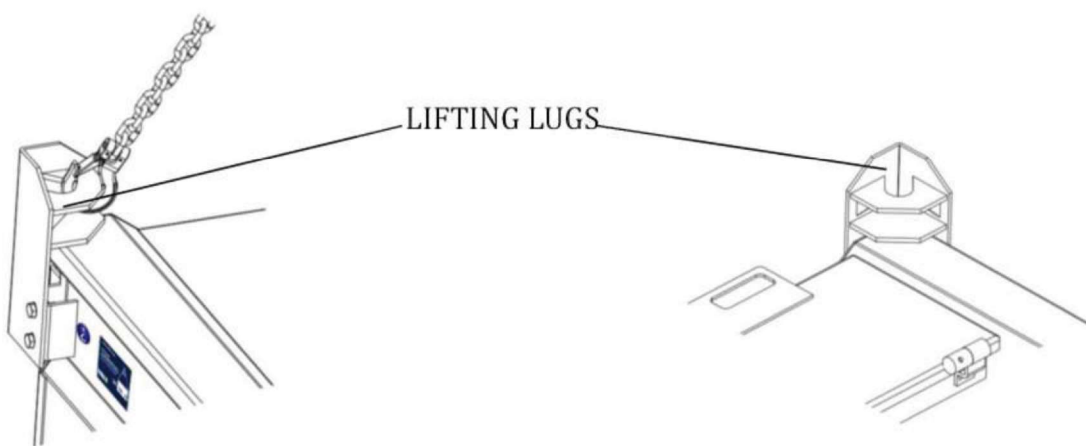
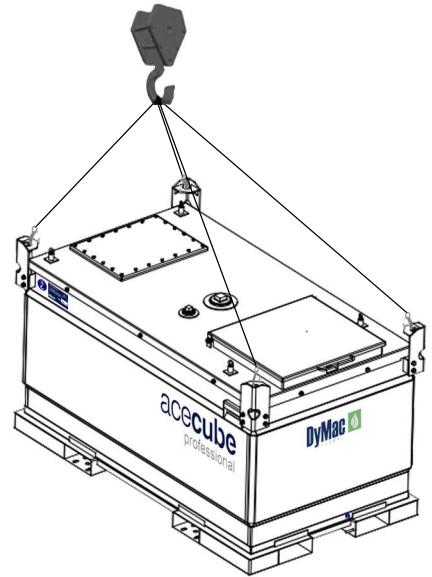

*Image may not represent your exact tank model

WARNING

Only properly trained and licensed crane operators who have knowledge of hazardous material handling should transport AceCube. Never allow anyone to place any part of their body beneath a lifted load. Only use approved lifting cranes and hardware whose maximum weight limit exceeds 3 tons.

6. TRANSPORTATION & HANDLING

6.3 REMOVING THE INNER TANK

1. Remove all four stacking corners
2. Lift on all four corners using crane with hooks on the ends of the slings

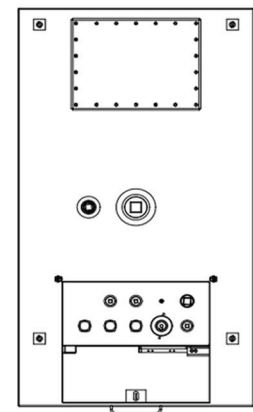
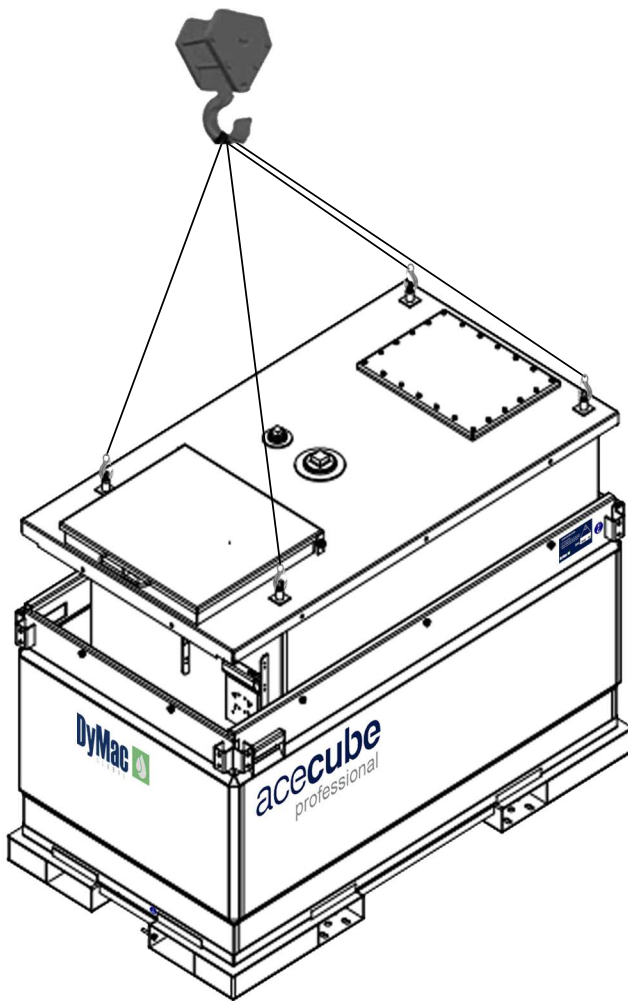

PLAN VIEW

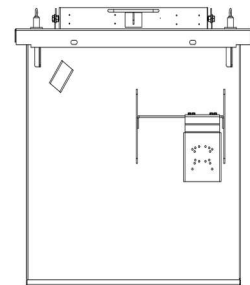

FRONT VIEW

*Image may not represent your exact tank model

WARNING

Only remove inner tank when empty.

6. TRANSPORTATION & HANDLING

6.4 TRAILER MOUNTING



Tank to be lowered onto trailer using hoist or crane by securely lifting on 4 lifting points on top of the tank. M20 Grade 10.9 plated bolts to be inserted into the predrilled holes in the forklift pockets to match with holes in trailer mounting brackets.

Bolts to be torqued to maximum 480 Nm or 354 ft-lb.

Bolts to be periodically checked before and after transport.

Maximum Recommended Tightening Torques		
Metric Course Pitch	Grade 10.9 Plated	
	Nm	ft-lb
M20	480	354

4 X M20 GRADE 10.9 BOLTS, NYLOCK NUTS AND PLAIN WASHERS TO FIX TANK TO AN APPROPRIATE DYMAC TRAILER. TRAILER SHOULD HAVE MAX GROSS WEIGHT TO MAX FULLY LADEN CAPACITY AS INDICATED ON THE UN NAME PLATE.

WARNING

Only properly trained and licensed crane operators who have knowledge of hazardous material handling should transport AceCube. Never allow anyone to place any part of their body beneath a lifted load. Only use approved lifting cranes and hardware whose maximum weight limit exceeds 3 tons.

7. DECLARATION OF CONFORMITY

We declare that the products listed are named as follows:

- AceCube Professional

Comply in whole or in part with the following standards:

- CAN/CGSB-43.146-2016-IBC type UN 31A/Y (ACP-500L to ACP-3000L).
- UL 142 & ULC S-601 (ACP-500L to ACP-5300L).
- Adhering to ADR regulations (ACP-500L to ACP-3000L).
- TSSA ON Canada (Optional).
- PPG26.
- PPG2 Oil Prevention Regulations 2001 (England & Wales).
- EC Directive 2007/46/EC as amended.

Product Description: Bulk Fuel Storage Tank Design

Issue Date : 09/11/2021

Checked Date : 09/11/2021

Approved Date : 09/11/2021

Director, Signed

Martin Laverty

Production Manager, Signed

[Signature]

DyMac Global Ltd

Long lane farm, Ascot Road, Holyport, Maidenhead, Berkshire, SL6 3LG,
United Kingdom.



Fuelling Your Progress

DyMac Global LTD / DYMAC UK

E: sales@dymacglobal.com

T: +44 300 303 3353

LONG LANE FARM

ASCOT ROAD, HOLYPORT

MAIDENHEAD

BERKSHIRE SL6 3LG

UNITED KINGDOM

DYMAC INDIA PVT

E: india@dymacglobal.com

T: +918243559370

CITY GATE COMMERCIAL

COMPLEX, FOURTH FLOOR

KADRI TOLL GATE, KADRI

MANGALORE - 575002

INDIA

DYMAC CANADA INC

E: canada@dymacglobal.com

T: +1905 564 3654

MISSISSAUGA

TORONTO

CANADA

DYMAC IRELAND

E: ireland@dymacglobal.com

T: +353 1 442 0516

BROWNSTOWN ROAD

COMMONS, NEWCASTLE,

CO. DUBLIN,

D22 Y2F2

IRELAND

DYMAC USA INC

E: usa@dymacglobal.com

T: +1 905 564 3654

3028 GREENMOUNT AVE #2038

BALTIMORE, MD

UNITED STATES 21218