

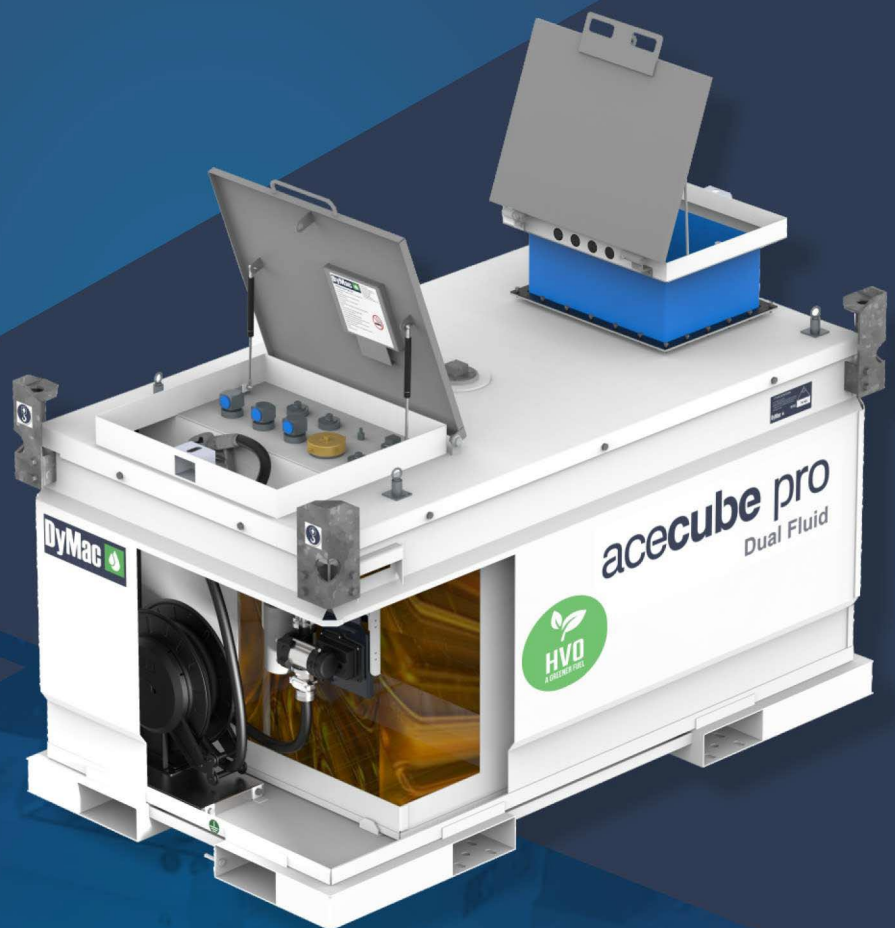

The AceCube Professional Dual Fluid is a transportable cube style tank range.



Available Sizes

- ✓ ACP-DF-680-140L
- ✓ ACP-DF-1750-140L
- ✓ ACP-DF-2570-280L
- ✓ ACP-DF-4080-280L
- ✓ ACP-DF-4820-280L

acecube pro
Dual Fluid



acecube pro

Dual Fluid

Enhanced Design Features

Unique Design Standard

The AceCube Pro dual fluid Tank comes complete with galvanized hippo lid, hatch lid and galvanized stacking corners. The innovative design also allows the primary hippo lid to open up to a component ports plate with access to an extra large equipment compartment area. The ACP-DF range has been fitted with secondary plate as standard opening. The secondary hatch opening allows the fitting of an Ad-blue / DEF insert tank and dispensing kit.

Transportable & Portable

The AceCube Pro Dual Fluid tank is an IBC Bunded Fuel Storage tank range and comes in the following sizes ACP-DF-680L/140L to ACP-DF-1750L/140L & ACP-DF-2570L/280L. The tanks come with UN31A/Y certifications adhering to ADR and (DOT) Department of transport regulations, guaranteeing them for safe and secure transportation on all major roadways when full of fluids. The ACP-DF-4070L/280L & ACP-DF-4820L/280L are stationary tanks.

Maintenance & Environment

To ensure efficient and effective cleaning, maintenance and inspection procedures. The AceCube Pro Dual Fluid tank design has an ingenious two tier component design. This flexible design also ensures a minimal amount of downtime when going through end of life refurbishment and thus increases over long term ROI.

Dispensing & Accessibility

The AceCube Pro Dual Fluid Tank comes equipped with a spacious equipment chamber which engages a bespoke universal bracket plate system that can support various retractable hose reels, along with a variety of electric pumps, dispensing kits and rotary hand pumps.

Stacking & Racking

All AceCube Pro Dual Fluid tank designs are "Stackable and Rackable" into 40ft shipping containers for world wide transports. They are also stackable 2 high when empty and 1 high when full.

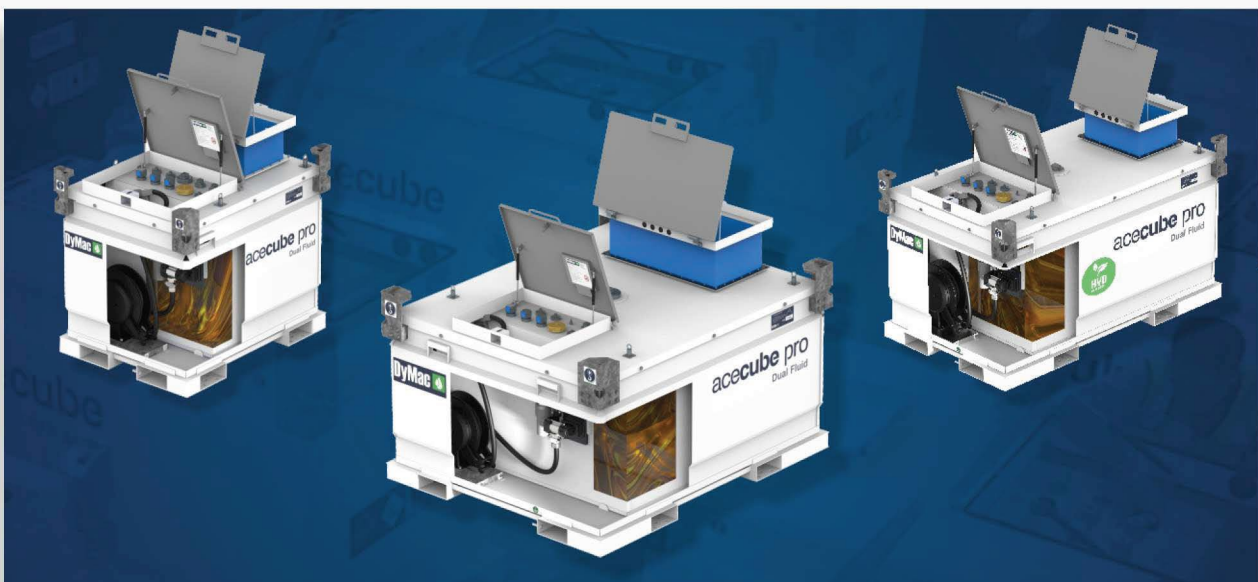

Design Innovation

Take a look inside

The AceCube Pro Dual Fluid tank range boasts a bi-directional forklift pocket design and comes with internal baffle plates for protection against sloshing when transporting. The range has a stacking corners that double up as lifting lugs providing total ease of maneuverability. There are conveniently positioned ports & fittings underneath the primary hatch lid that also opens up to an extra-large equipment compartment area.

It also comprises a secondary opening at the rear to allow the fitting of a 140L Ad-blue/DEF Poly Plastic insert HPDE tank. Thus, providing a unique dual fluid tank design.

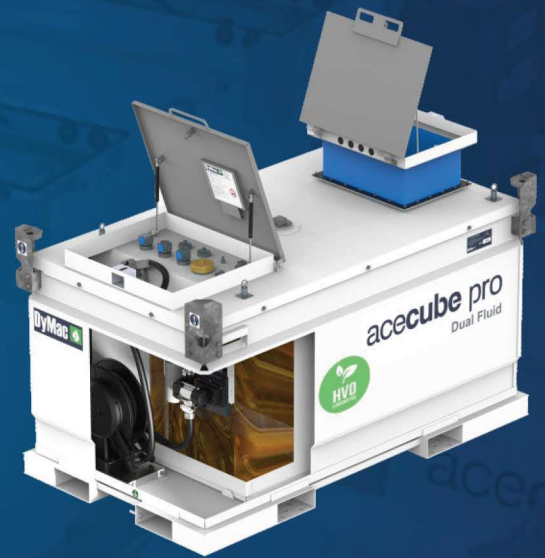

Designed For Diesel Dispensing



Can accommodate up to 10M or 40ft retractable hose reel mounted in the bundled equipment compartment.



Automatic dispensing nozzle with 4m or 8ft hose and various electric pump size options.

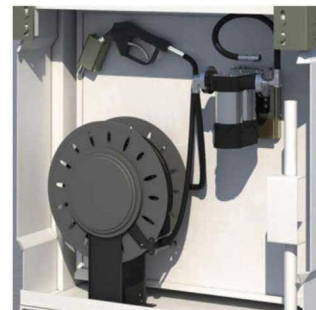

Combined 10M/32ft retractable hose reel option with Automatic Dispensing nozzle.

Designed for Ad-blue DEF Dispensing



Multiple ports can be connect up to three pieces of machinery at one time and allow dispensing simultaneously.



280L/ 140L Poly Plastic inner tank surrounded in a carbon steel sump protection tank.



12V Ad/blue dispensing pump with delivery nozzle and hose.

acecube pro

Dual Fluid

Model ACP-DF-680L/140L (180G/37G)

The AceCube Pro Dual Fluid ACP-DF-680L/140L tank is designed for the safe and secure transporting and storage of various industrial lubricants and hazardous liquids worldwide.



Specifications

	Metric	US	Imperial
Capacity	680 Litres	180 Gallons	150 Gallons
Length	1485 mm	58"	58"
Width	1150 mm	45"	45"
Height	1295 mm	51"	51"
Bund Tank Material	3 mm	1/16"	1/16"
Inner Tank Material	4 mm	2/16"	2/16"
Mass (empty)	589 kg	1298 lbs	1298 lbs
Mass (full)	1329 kg	2930 lbs	2930 lbs
Safe Fill Level	646 Litres	170 Gallons	35 Gallons

Approvals and Certifications

UK & Europe

- ✓ UN 31 A/Y Compliant Design
- ✓ UL 142 Compliant Design
- ✓ Pressure Tested
- ✓ Adhering to ADR regulations

USA & Canada

- ✓ UN 31 A/Y Compliant Design
- ✓ UL 142 Compliant Design
- ✓ Pressure Tested
- ✓ Adhering to ADR regulations

Plastic Ad-Blue DEF 140 Litres/37 Gallons

Specifications

	Metric	US
Capacity	140 Litres	37 Gallons
Length	714 mm	28"
Width	514 mm	29"
Height	949 mm	37"
Bund Tank Material	4 mm	15"

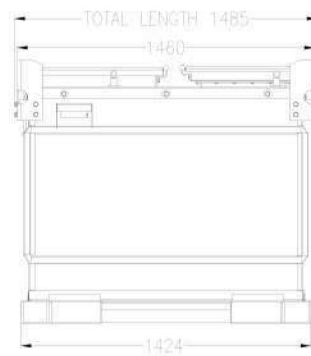

The range has an extra large equipment compartment area that can house a variety of accessories.



DISPENSING NOZZLE VARIATIONS



HOSES WITH ISO QUICK RELEASE COUPLERS



UP TO 10M OR 32FT RETRACTABLE HOSE REELS



DIGITAL FLOW METERS



ENGINE DRIVEN OR ELECTRIC PUMPS



IN LINE PARTIAL SEPARATION FILTERS

Model ACP-DF-1750L/140L (462G/37G)

The AceCube Pro Dual Fluid ACP-DF-1750L/140L tank is designed for the safe and secure transporting and storage of various industrial lubricants and hazardous liquids worldwide.

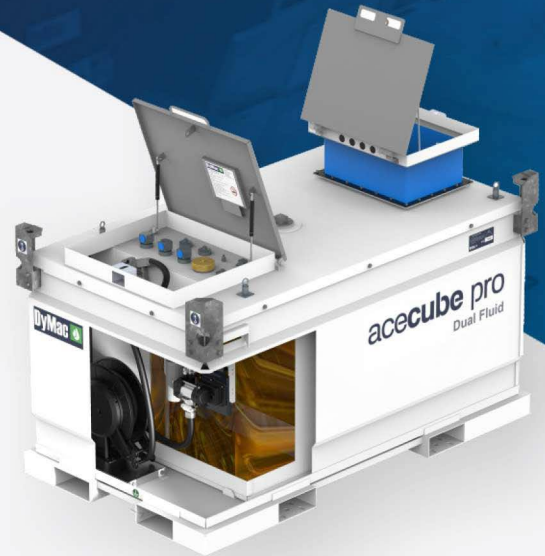

Specifications

	Metric	US	Imperial
Capacity	1750 Litres	198 Gallons	165 Gallons
Length	2300 mm	90.5"	90.5"
Width	1325 mm	52"	52"
Height	1295 mm	51"	51"
Bund Tank Material	3 mm	1/16"	1/16"
Inner Tank Material	4 mm	2/16"	2/16"
Mass (empty)	837 kg	1845 lbs	1845 lbs
Mass (full)	2436 kg	5370 lbs	5370 lbs
Safe Fill Level	1658 Litres	438 Gallons	365 Gallons

Approvals and Certifications

UK & Europe

- ✓ UN 31 A/Y Compliant Design
- ✓ UL 142 Compliant Design
- ✓ Pressure Tested
- ✓ Adhering to ADR regulations

USA & Canada

- ✓ UN 31 A/Y Compliant Design
- ✓ UL 142 Compliant Design
- ✓ Pressure Tested
- ✓ Adhering to ADR regulations

Plastic Ad-Blue DEF 140 Litres/37 Gallons

Specifications

	Metric	US
Capacity	140 Litres	37 Gallons
Length	714 mm	28"
Width	514 mm	29"
Height	949 mm	37"
Bund Tank Material	4 mm	15"

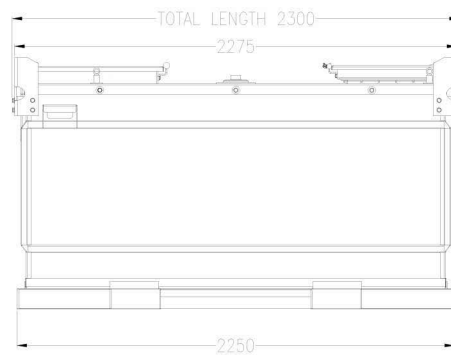

The range has an extra large equipment compartment area that can house a variety of accessories.



DISPENSING NOZZLE VARIATIONS



HOSES WITH ISO QUICK RELEASE COUPLERS



UP TO 10M OR 32FT RETRACTABLE HOSE REELS



DIGITAL FLOW METERS

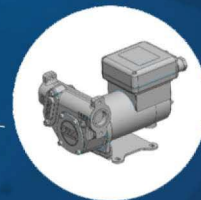

ENGINE DRIVEN OR ELECTRIC PUMPS



IN LINE PARTIAL SEPARATION FILTERS

Model ACP-DF-2570L/280L (679G/74G)

The AceCube Pro Dual Fluid ACP-DF-2570L/280L tank is designed for the safe and secure transporting and storage of various industrial lubricants and hazardous liquids worldwide.



Specifications

	Metric	US	Imperial
Capacity	2570 Litres	679 Gallons	565 Gallons
Length	2300 mm	90.5"	90.5"
Width	1885 mm	74"	74"
Height	1295 mm	51"	51"
Bund Tank Material	3 mm	1/16"	1/16"
Inner Tank Material	4 mm	2/16"	2/16"
Mass (empty)	1109 kg	2445 lbs	2445 lbs
Mass (full)	3538 kg	7800 lbs	7800 lbs
Safe Fill Level	2442 Litres	645 Gallons	537 Gallons

Approvals and Certifications

UK & Europe

- ✓ UN 31 A/Y Compliant Design
- ✓ UL 142 Compliant Design
- ✓ Pressure Tested
- ✓ Adhering to ADR regulations

USA & Canada

- ✓ UN 31 A/Y Compliant Design
- ✓ UL 142 Compliant Design
- ✓ Pressure Tested
- ✓ Adhering to ADR regulations

Plastic Ad-Blue DEF 280 Litres/74 Gallons

Specifications

	Metric	Metric
Capacity	280 Litres	37 Gallons
Length	857 mm	28"
Width	414 mm	29"
Height	1040 mm	37"
Bund Tank Material	4 mm	15"

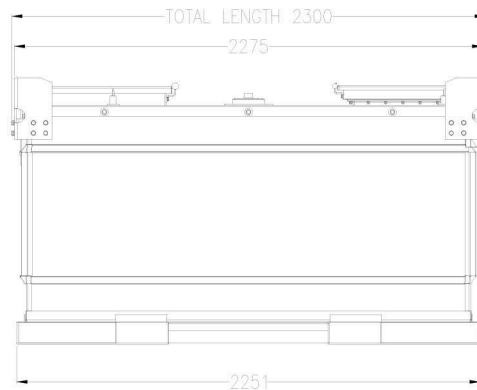
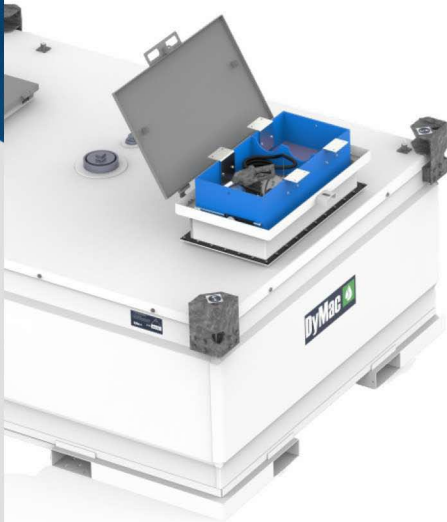

The range has an extra large equipment compartment area that can house a variety of accessories.



DISPENSING NOZZLE VARIATIONS



HOSES WITH ISO QUICK RELEASE COUPLERS



UP TO 10M OR 32FT RETRACTABLE HOSE REELS



DIGITAL FLOW METERS

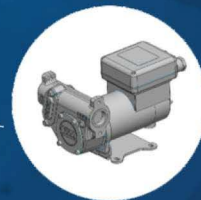

ENGINE DRIVEN OR ELECTRIC PUMPS



IN LINE PARTIAL SEPARATION FILTERS