



AUTHOR: JERRY SCANNELL  
APPROVED BY: JS / SW  
REV NO: R1.0  
REV DATE: 04/09/2018

**Tank Specification**

Length: 1720 mm  
Width: 1060 mm  
Height: 1020 mm

Product Mass: 46 kg

Capacity Brimful: 1184 litres  
Capacity Nominal: 1125 litres

Material Tank: MDPE

Approval Number: 0654070503R (OFTEC)

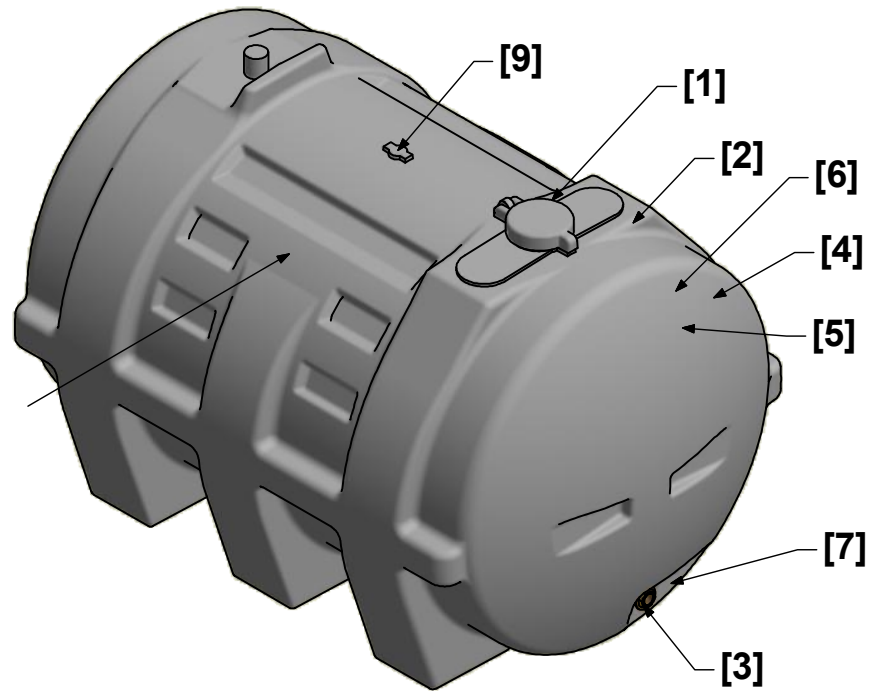

**Equipment**

- 1. 5" (~125mm) Inspection Lid - Lockable
- 2. Tank Serial Number Stamp
- 3. 1" (~25mm) Bottom Outlet
- 4. CE Label
- 5. Installation Instructions
- 6. Handle With Care Label
- 7. Left Hand Thread Label
- 8. Product Label
- 9. Ultrasonic Contents Gauge Location

**STGR00650R-OFT [OFTEC UK]**

- 10. 2" BSP (~50mm) Vent
- 11. 2" BSP (~50mm) Offset Fill Connection - Lockable

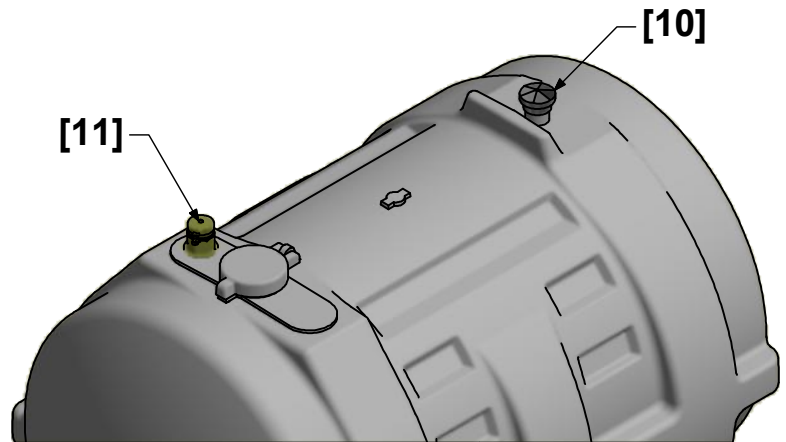

**Installation & Siting Guidelines**

Carbery Tanks must only be installed and commissioned by a suitably competent person in accordance with supplied instructions and all prevailing statutory requirements.

Please Consult the Installation, Operation and Maintenance Manual for further Information.

**Certification**

All Carbery Plastics LTD tanks are certified to EN13341.