

FUEL STORAGE TANK FUEL CONDITIONER - RE-CIRCULATION KIT. ADVANCED.

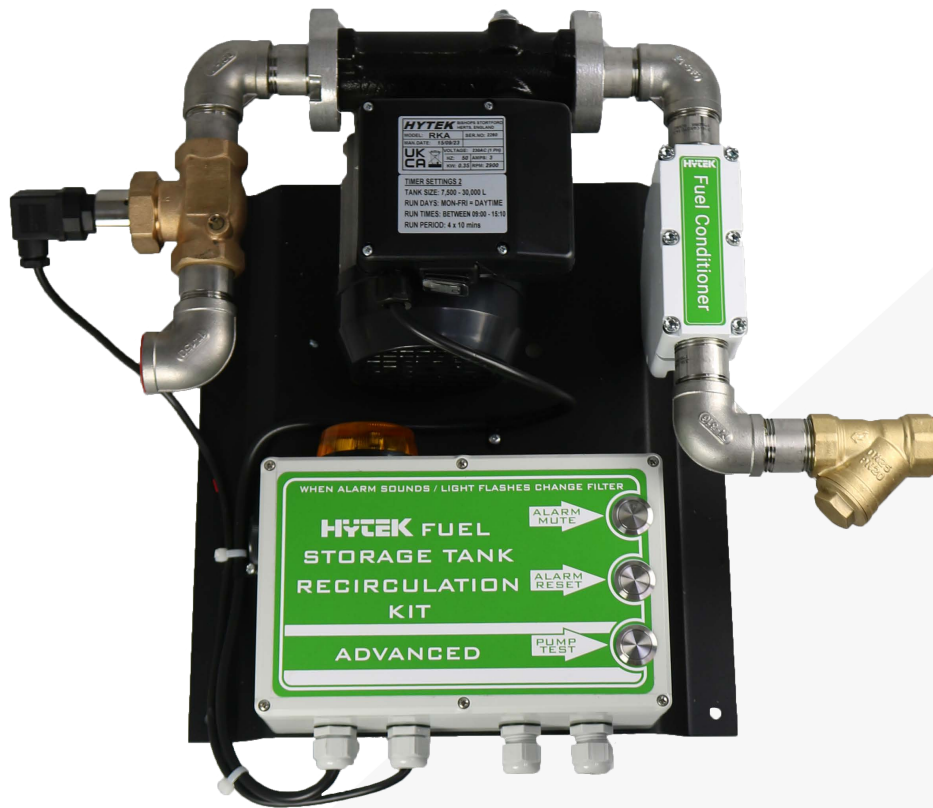

Applies to the following models **ONLY**:

RKA

Please read carefully **BEFORE** commencing installation.

Registered Office: HYTEK (GB) LIMITED,
Delta House, Green Street, Elsenham, Bishop's Stortford,
CM22 6DS UK.

Registered in England No. 1915382

Tel: +44 (0) 1279 815 600

Email: info@hytekgb.com

ENVIRONMENTAL INFORMATION

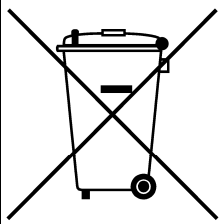

UK Regulation SI 2013 3113 requires that the equipment bearing this symbol on the product and/or its packaging must not be disposed of with unsorted municipal waste. The symbol indicates that this product must be disposed of separately from regular household waste streams. It is your responsibility to dispose of this and other electric and electronic equipment via designated collection facilities appointed by the government or local authorities.

IMPORTANT WARNING NOTES

1. This recirculation kit **MUST NOT** be used to dispense petrol or other flammable liquids.
2. It must not be sited adjacent to a petrol dispenser or in any other hazardous zone.
3. On above ground storage tanks an angle check valve fitted with the appropriate spring or pressure regulating valve must be fitted at the tank outlet to prevent loss of fuel under gravity in the event of vandalism or accidental damage.
4. Ensure the installation pipework does not place any undue stress on the recirculation kit. If necessary, connect using flexible hoses with swivel end fittings
5. Installation of this equipment and its associated tank, pipe work and fittings should only be carried out by qualified fuel installation engineers.
6. The installation must conform to all relevant electrical and local authority regulations and standards.
7. It must not be used with other liquids or for other applications. We will accept no warranty claims or liability if it is used for other liquids or applications.
8. This kit must be installed in a well-ventilated area.

PRODUCT DESCRIPTION

The range of Hytek Fuel Storage Tank Recirculation Kits are designed to circulate and prevent premature degradation of the fuel inside a bulk storage tank. As it is circulated the fuel is passed through a conditioner that prevents harmful microbial growth within the fuel itself. There is also the option to fit a bowl filter that removes any water and particular contamination from the fuel as it passes through.

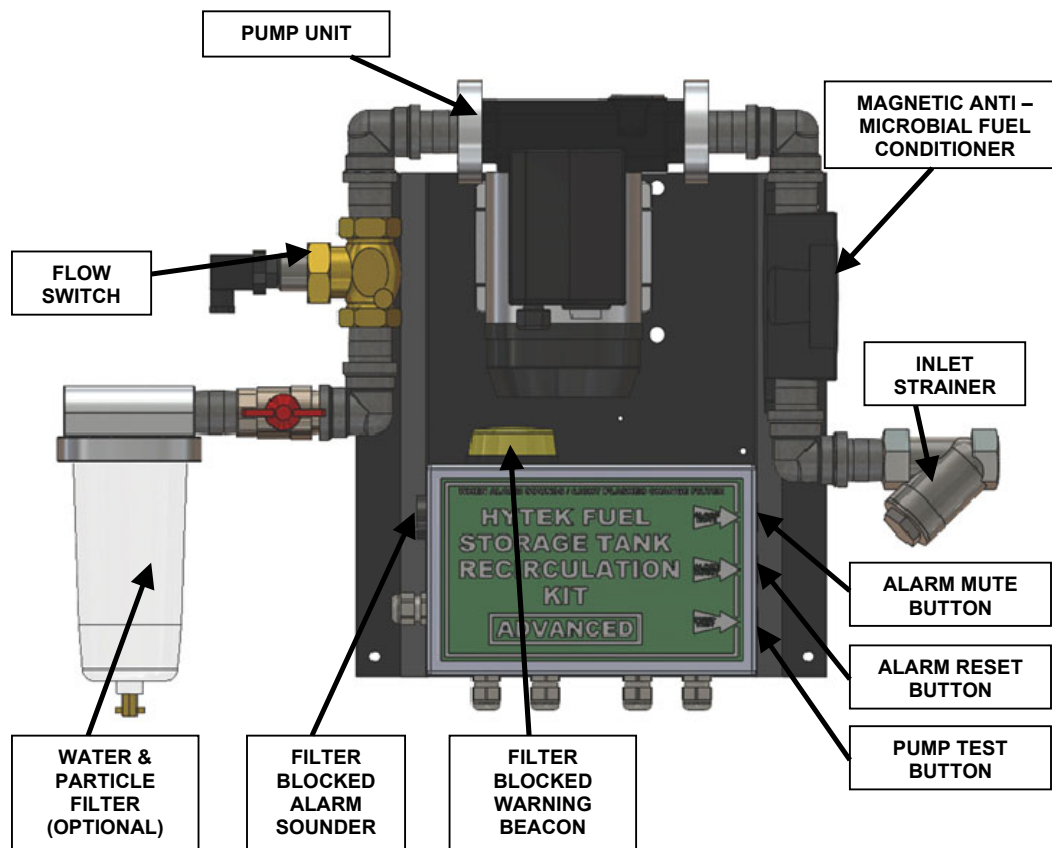

SPECIFICATION

- Suitable for re-circulating diesel or gas oil.
- The kits are weatherproof and fitted to a compact back plate for wall mounting.
- The fuel is automatically circulated for a preset number of time periods, throughout the working day, to ensure the fuel is conditioned to the required level.
- In addition to the inlet strainer supplied as standard there are three water and particle filter options available which can be fitted to the outlet:
 - FM.RK.F - 10 micron filter kit
 - RKF2 - 2 micron filter kit (standard capacity)
 - RKF2H - 2 micron filter kit (high capacity)
- In the event of the circulation being reduced, due to clogging of the filters, a warning light and sounder, fitted to the unit, will activate.
- In addition to the visible and audible warnings, connections are included to allow the kit to be linked to an alarm or fuel management system to provide a remote warning.
- Connections are also included to provide a remote indication that the pump is running.
- Performance: **ADVANCED KIT (RKA)** Suitable for circulating up to 5000 litres of fuel per day (65,000L capacity tank).

INSTALLATION INSTRUCTIONS

1. Before installation, clean any threaded joints to ensure that no dirt or debris is present.
2. Mount the unit via the four mounting holes on the back plate.
3. Connect the female Y-strainer inlet to a suitable tank outlet. Ensure that the thread is sealed with a suitable thread sealant. It is recommended that an isolation valve is installed in the pipework connected to the inlet of the unit.
4. Connect the 1" BSP female outlet of the unit to a suitable tank inlet. If one of the optional water and particle filters is to be fitted connect this to the outlet and then connect the filter outlet to the tank inlet. Ensure the threads are sealed with a suitable thread sealant.
5. Ensure the installation pipework does not place any undue stress on the recirculation kit. If necessary connect using flexible hoses with swivel end fittings
6. Connect a suitable 230V AC power supply, fused at 13 amps, into the junction box provided as follows:
230v AC: Brown – Live, Blue – Neutral, Yellow/Green – Earth
7. The pump may now be primed using the pump test button.

CONNECTION TO CONTROL SYSTEM

The unit can be connected to an alarm or management system to provide a remote warning when the filter becomes blocked. Connections are also provided to indicate that the recirculation pump is running. Both pairs of contacts are normally open, passive switched outputs located inside the junction box, which are clearly labelled. They are rated at 240V / 10A max.

WIRING DETAILS

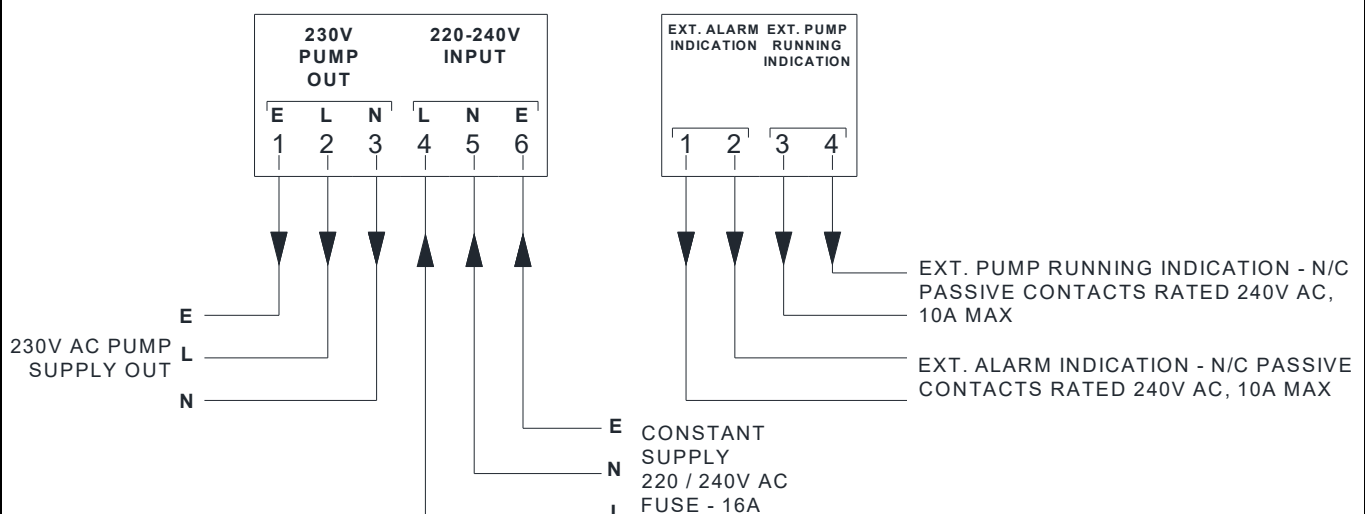

INSTRUCTIONS FOR USE

The pump unit is designed to run automatically and unattended. The timer unit is pre-programmed by Hytek so that it runs at pre-set intervals throughout the. The electronic timer instructions are supplied if any adjustments need to be made. The pre-set times are as per questionnaire received and shown on the timer sticker on the junction box.

The unit is fitted with a flow switch connected to an alarm warning light and sounder to indicate when the flow rate has dropped due to the inlet/outlet filter becoming blocked. The low flow rate alarm will only activate when the recirculation pump is running, either during one of the pre-set intervals or when the Pump Test button is pressed. The alarm will remain active after the pump has stopped running at the end of the pre-set interval but pressing the Alarm Mute button will silence the alarm and keep the warning light flashing. To cancel and reset the alarm after the pre-set interval press the Alarm Reset button. Pressing the Alarm Mute button during the pre-set interval will have no effect and the sounder will remain activated.

When the recirculation pump is running the external pump running contacts are closed. When the unit is in an alarm state (warning light flashing) the external alarm contacts also remain closed.

DIMENSIONS

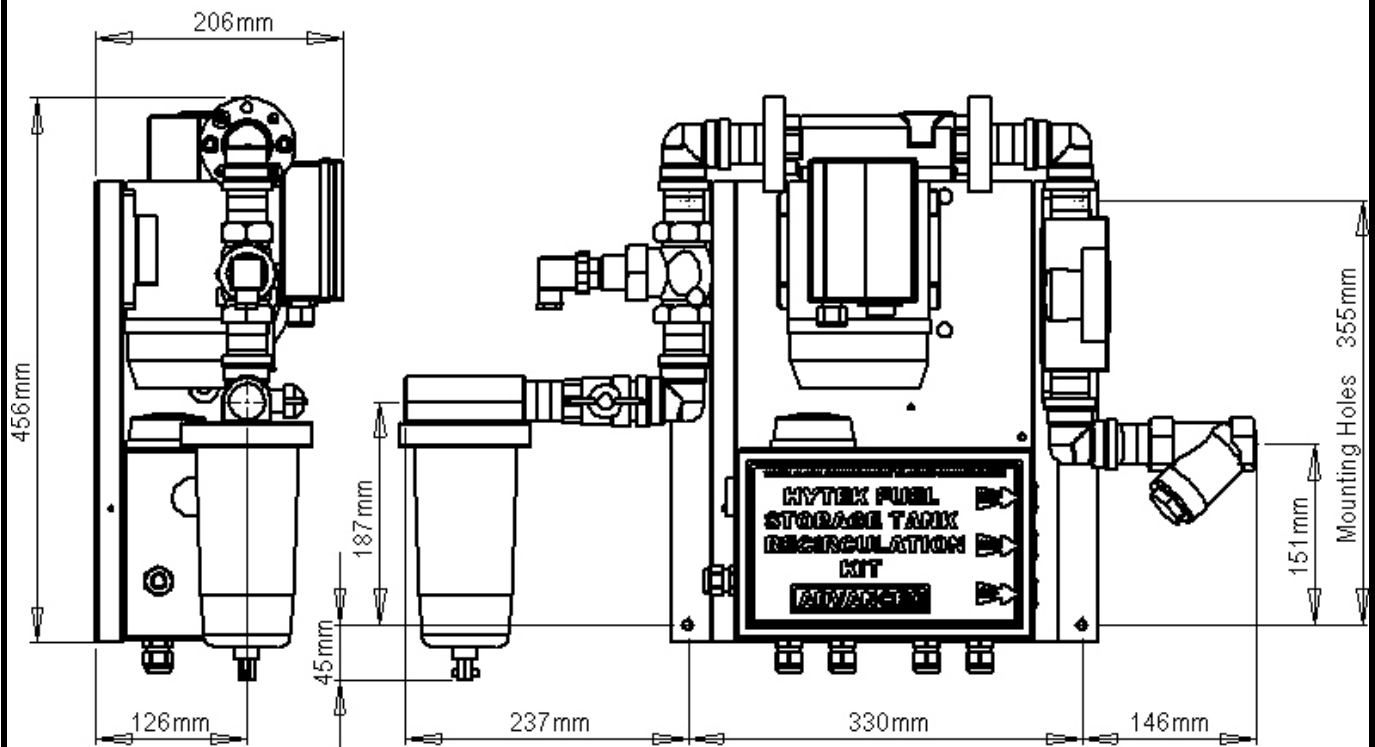

MAINTENANCE AND FILTER CHANGING

The unit is fitted with a sounder and warning light to indicate when the flow rate has dropped due to the inlet/outlet filter becoming blocked. This indicates that either the optional filter on the outlet needs changing or the brass Y-strainer, fitted to the inlet, has become blocked. If the Hytek filter outlet kit is fitted to the pump unit then use the supplied filter wrench to remove the filter bowl and replace the filter.

IMPORTANT: Ensure that the power to the pump unit is isolated whilst the filter is being changed to ensure that the pump does not activate via the timer. Also ensure that any valves are closed on the inlet pipe work to prevent fuel loss.

WARNING: DO NOT ADJUST THE SCREW ON THE FLOW SWITCH AS THIS IS FACTORY PRESET AND ANY ADJUSTMENT WILL AFFECT PERFORMANCE.

SPARE PARTS

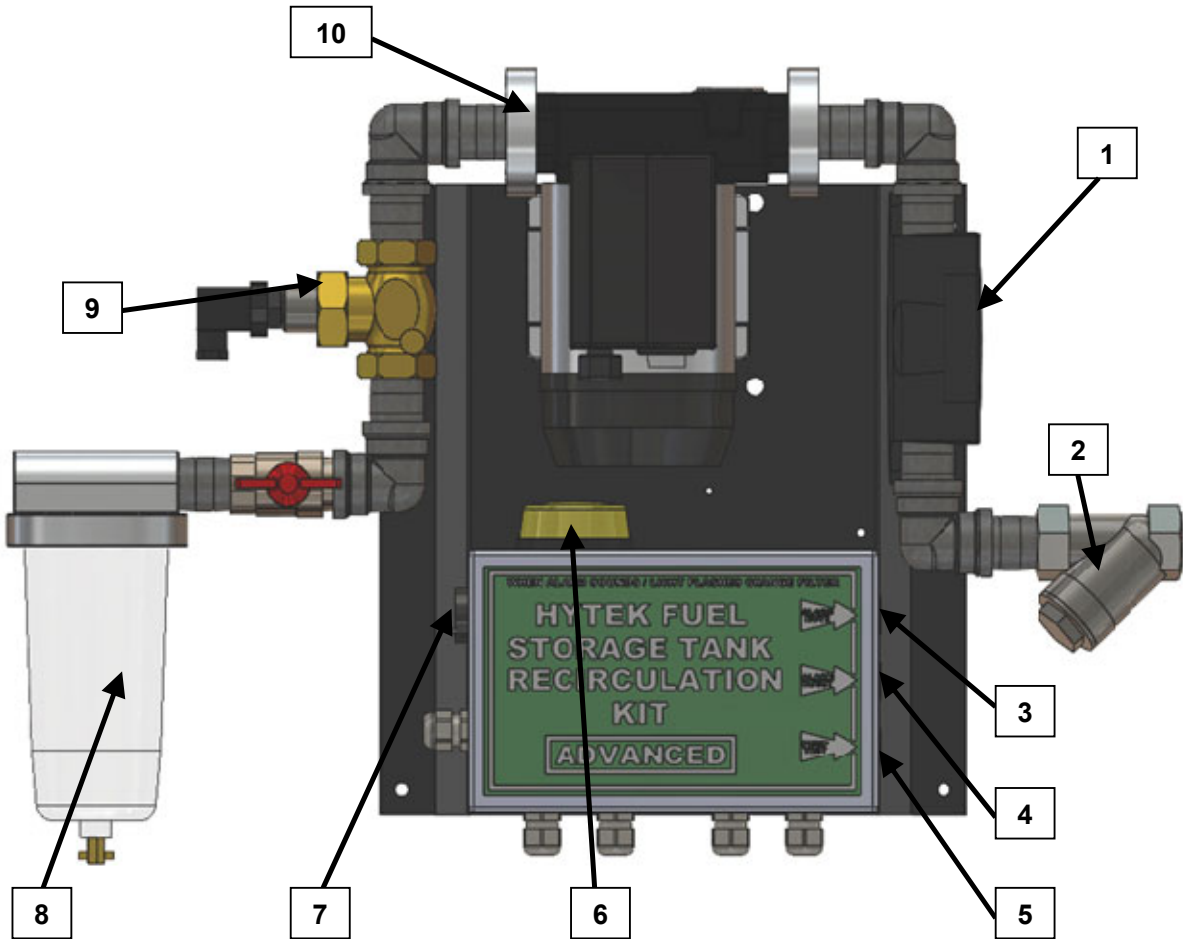

REF NO	DESCRIPTION	STOCK CODE
1	MAGNETIC FUEL CONDITIONER	PFFC
2	INLET Y-STRAINER	YSTR.1
3	ALARM MUTE BUTTON	RKA.BUTT
4	ALARM RESET BUTTON	RKA.BUTT
5	PUMP TEST BUTTON	RKA.BUTT
6	ALARM WARNING FLASHING LIGHT	TA.BEACON
7	ALARM WARNING SOUNDER	TA.SOUND
8A	REPLACEMENT WATER/PARTICLE FILTER 10 MICRON	FFILT.ELW2
8B	REPLACEMENT WATER/PARTICLE FILTER 2 MICRON STANDARD CAPACITY	HYD.ELB2
8C	REPLACEMENT WATER/PARTICLE FILTER 2 MICRON HIGH CAPACITY	HYD.EL800B2
9	FLOW SENSOR	FM.RK.FS
10	PUMP UNIT	SPT56
	ITEMS IN CONTROL BOX	
	TIME SWITCH	FM.RK.TS
	RELAY	RKA.RELAY
	PUMP RELAY	RKA.RELAY.P
	ITEMS NOT SHOWN	
	FILTER BOWL WRENCH	FFILT.WP

DECLARATION OF CONFORMITY



Company Name: **Hytek (GB) Ltd**

Address: **Delta House
Green Street
Elsenham
Bishop's Stortford
Hertfordshire
CM22 6DS**

Date of Issue: **25th October 2022**

Equipment Details: **Fuel Tank Hygiene Re-Circulation Kit Range
FM.RKS, FM.RKH, FM.RKS.JO020, RK, RKA**

Applicable Directives:
& Standards

- SI 2016 1091 Electromagnetic Compatibility Regulations**
- SI 2016 1101 Electrical Equipment Safety Regulations**
- SI 2008 1597 Supply of Machinery Safety Regulations**
- SI 2016 1105 Pressure Equipment Safety Regulations**
- SI 2013 3113 Waste Electrical & Electronic Equipment Regulations**
- SI 2012 3032 Restriction of Use of Certain Hazardous Substances Regulations**

Declaration Number: **UK096 Issue 6**

On behalf of the above-named company, I declare under our sole responsibility that, on the date the equipment accompanied by this declaration is placed on the market, the equipment conforms with all technical and regulatory requirements of the above listed directives.

A handwritten signature in cursive script that reads "Clive Wellings".

Clive Wellings, Process Co-ordinator
25th October 2022,
Bishop's Stortford, Herts

THE INFORMATION CONTAINED IN THIS DOCUMENT IS PROTECTED BY COPYRIGHT © AND PROPERTY LAWS AND IS THE SOLE PROPERTY OF HYTEK (GB) LTD. ANY REPRODUCTION IN PART OR AS A WHOLE WITHOUT THE WRITTEN PERMISSION OF HYTEK (GB) LTD IS PROHIBITED.