

FUEL TANK SHOP

# Putting your Oil Storage in Safe Hands



1052454\_01

**FTS**

These instructions should be read in their entirety before commencing installation of the tank.

- A risk assessment must be carried out with reference to OFTEC TI/133D in Technical Book 3 to determine if the installation requires a bunded tank.
- Installation should meet current Building Control / Environment Agency / Pollution Control guidelines.
- Refer to OFTEC Technical Book 3 and BS5410 : Part 1 and Part 2 for requirements on location, installation and maintenance.
- For all tank installation and maintenance, please take into consideration Health & Safety / Local Building Regulations.
- Indoor installations need to meet BS5410, Parts 1 and 2 and OFTEC Technical Book 3.
- For commercial and industrial installations refer to BS5410 : Part 2 and OFTEC Technical Book 3.
- For agricultural installations refer to OFTEC Technical Book 3.
- Where the tank has to be raised above ground level to provide a gravity flow of oil to an appliance the installation should meet OFTEC guidelines and BS5410 : Parts 1 and 2.
- The tank must be installed directly on a level, secure and non-combustible base. If the tank is raised to provide a gravity oil supply, the base must be raised also so that the tank is installed directly on it. Please refer to OFTEC Technical Book 3.
- Determine if tank needs to be secured in place in exposed conditions. Do not drill holes in the tank.
- All associated pipe work must be supported independently so as not to put any strain on the tank.
- For vapourising appliances bottom outlets are preferred, however, if a top outlet tank is used a lift pump will be required – consult the appliance manufacturer for technical advice.
- For bottom outlet, the length of pipe run, tank height and boiler requirements will determine the outlet size. Top outlets are treated as a separate item (see table 1).

- Buried pipe work needs to meet OFTEC Technical Book 3 and BS5410 : Part 1.
  - Single skin tanks and EcoSafe bunded range of tanks may be fitted with bottom or top outlets, although the Environment Agency prefers top outlet tanks.
  - Prior to installing inspect for damage, if damaged do not install.
  - Connections must be held in place when tightening. Do not over tighten.
  - Use only approved sealing compound such as Heldite or similar.
  - Never solder joints / connections.
  - The guarantee card in this booklet should be returned to the manufacturer or it can be completed online at [www.kingspanenergymanagement.co.uk/warranty](http://www.kingspanenergymanagement.co.uk/warranty).
  - The tank serial number must be recorded on the guarantee card to validate warranty. This number is usually located around lid area and on larger tanks on the rib above the outlet.
  - The tank must be installed by a suitably qualified engineer with OFTEC registration or equivalent.
  - The warranty is dependant on the tank being correctly installed and maintained by a suitably qualified engineer.
  - *THE TANK MUST NOT BE FILLED AT A RATE EXCEEDING 400 LITRES PER MINUTE.*
  - For further advice, contact the OFTEC helpline on 0845 6585 080 or visit [www.oftec.org](http://www.oftec.org)
- After installation, please ensure that this instruction booklet is left with the the end user for future reference.**

- Tanks with a capacity not exceeding 3,500 litres (serving single family dwellings and where the boiler output does not exceed 45 kW) should be fitted not less than 1.8 metres from a building, and not less than 760mm from the site boundary and not less than 1.8 metres from a flue outlet. (See figure 1 on page 6).
- Where the above clearances cannot be achieved, the protection measures noted in BS5410 : Part 1 must be provided by means of a 30 minutes fire resistant wall which extends at least 300mm above and beyond the ends of the tank.
- It will be necessary to protect exposed eaves forming part of a roof within 1.8 metres of the top of an oil storage tank to provide 30 minutes fire resistance. Cladding should be applied to the eaves in order to prevent fire spreading to the roof.
- Larger houses with a capacity in excess of 3,500 litres, or where the boiler output exceeds 45 kW, have different requirements, and reference should be made to BS 5410 : Part 2 and OFTEC Technical book 3.

- For commercial and industrial installations refer to BS5410 : Part 2 and OFTEC Technical Book 3.
- For agricultural installations refer to OFTEC Technical Book 3.

**Ensure the entire base of the tank is supported with a non-combustible base (minimum 45mm in thickness) extending 300mm on all sides.**

**Figure 1:** Class 1 Tank Installation near combustible buildings and boundaries with clearances required when additional fire protection is not provided. (Printed with the permission of OFTEC)

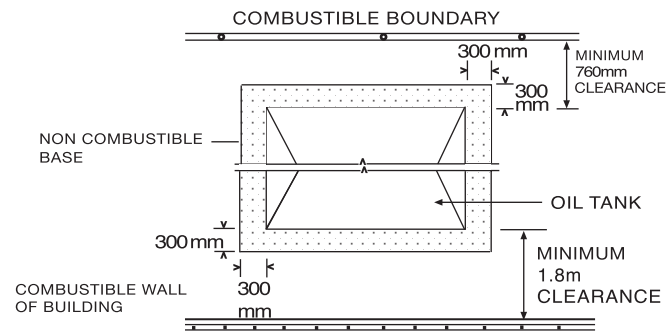
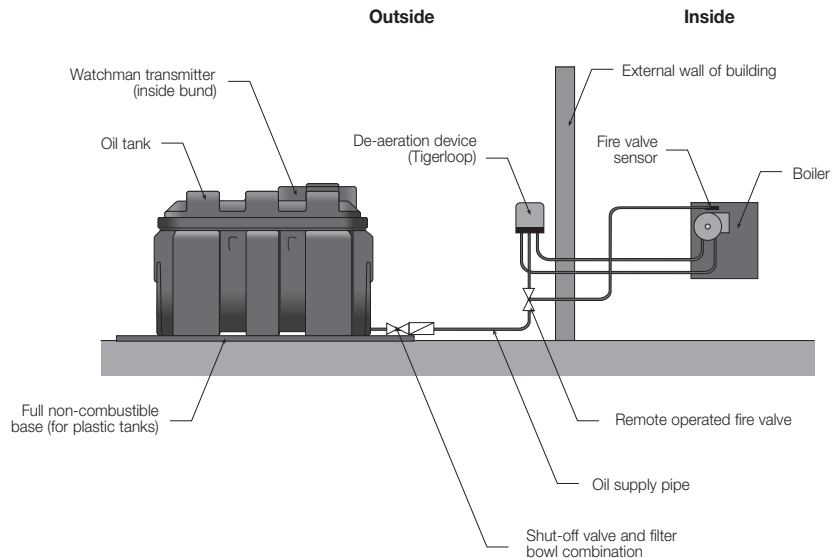

Figure 2: Typical Bottom Outlet Arrangement



**SpillStop Information**

The SpillStop is an overfill prevention device that ensures the environment is protected if an attempt is made to overfill the tank. This device with a 2" BSP threaded connection shuts off the fill point once fuel reaches 95% of the tank volume (figure 6).

- Approved to BS EN 13616: for use in installations for the storage of fuel intended for the supply of building heating/cooling systems.
- Meets the requirements of OFTEC OFS T100.
- For use only with tanks filled by a pressure pump and a delivery hose with a shut-off valve, operating at a minimum of 150mbar (15kPa) and a maximum 6 bar (0.6MPa).
- Suitable for delivery fuel flow rates from 35 litres / minute up to 600 litres / minute. Note: General industry advice directs that plastic storage tanks must not be filled at a rate exceeding 400 litres / minute.
- SpillStop is guaranteed for one year.

**Operation / User Guide**

- Remove 2" yellow screwcap.
- Where possible, visually check the hole on the cone part of the SpillStop in case something has become trapped.
- Securely screw the 2" delivery hose to the SpillStop, the delivery hose must have a shut off valve.
- Fill tank in normal manner.
- When the SpillStop is activated, the delivery flow rate will be restricted to a maximum of 2.5 litres / minute.
- Close the shut off valve on the 2" delivery hose.
- Turn off the delivery pump.
- Wait 1 minute and then disconnect the delivery hose from the SpillStop.
- Securely fasten screwcap.

**Maintenance**

It is recommended where possible, that the hole in the centre of the cone shaped valve be checked during each annual tank check for any blockages. This is visible when looking down into the 2" threaded connection.

Figure 6: SpillStop overfill prevention device



Tank maintenance must be carried out annually by a suitably qualified engineer with OFTEC registration or equivalent. A check should be made on the following items;

- The general condition of the tank.
- Determine if there are any oil leaks.
- The tank for water ingress. Determine the cause and rectify.
- The condition of all pipework and fittings.
- The condition of filling and venting provisions.
- The condition of tank supports.
- The bunded tank: determine if any fluid is present in the bund, determine cause and rectify. Remove fluid as soon as possible and dispose of according to the requisite legislation.
- The condition of measuring devices.
- Check the filter bowl and replace parts as necessary. If spare parts are not readily available please contact Fuel Tank Shop.
- Ensure that the anti-siphon valve is working according to the manufacturer's instructions.
- Ensure that the Tigerloop de-aerator is working according to the manufacturer's instructions.
- Checks should be made on the condition of the SpillStop.

**Refer to OFTEC Technical Book 3 for further information on tank maintenance and inspection.**

The Fuel Tank Shop bunded oil storage tank is guaranteed for 10 years from the date of purchase against faulty materials or manufacture.

The guarantee applies to the original purchaser only, and is not transferrable to the subsequent owners.

Provided that the following criteria are adhered to (applicable to all models):

- The tank is installed and commissioned in accordance with the instructions outlined in the Installation and User Manual.
- The tank is installed and commissioned by a suitably qualified engineer.
- The tank is used for the storage of kerosene (C1/C2), fuel oil (A2), and gas oil/diesel (D), including bio diesel (HVO) as defined in BSEN2869, BSEN590 and BSEN15940. It should be noted that Titan tanks are not suitable for the storage of petrol or liquid petroleum gas (LPG).
- Proof of purchase and evidence of annual inspections by a suitably qualified service engineer are required in the event of a claim.
- The tank has not been subject to misuse, careless handling, faulty installation, or any repairs have not been attempted or carried out other than by Fuel Tank Shop service staff.
- The tank has been purchased by the end user and is not for hire purposes.
- The tank has not been filled at a rate exceeding 400 litres per minute.
- The tank is installed above ground.

- The tank is inspected annually by a suitably qualified service engineer, with records maintained. Immediately upon discovery of any defect in the tank, steps are taken to mitigate loss by contacting the oil supplier and if necessary arrangements are made for the tank to be drained pending the supply of a new tank.
- Immediately upon discovery of any defect you contact the Guarantor and allow a representative to inspect the tank and its surroundings and where necessary carry out any repairs (before any attempts are made to move the tank).
- The guarantee excludes ancillary fittings such as contents measuring gauges or mechanical pumps. Further guarantee information or ancillary fittings and pumps is provided within the manual.
- During the guarantee period, any component of your product which is provided to contain any material defect in workmanship or materials will be exchanged or repaired, at our sole discretion.

Product	Guarantee Period if Registered
Bunded Heating Oil Tanks	10 years



Ten year guarantee for bunded oil storage tanks



# Get the Right Tank at the Right Time at the Right Price

Visit [fueltankshop.co.uk](http://fueltankshop.co.uk)

Enjoy our full range on FuelTankShop:



Convenience -  
shop online 24/7



One stop shop -  
for purchasing  
and service



Genuine parts and  
spares - quality  
guaranteed



Product expertise  
directly from our  
customer service team



Trade terms available  
and flexible range of  
payment methods to  
choose from